

TCN

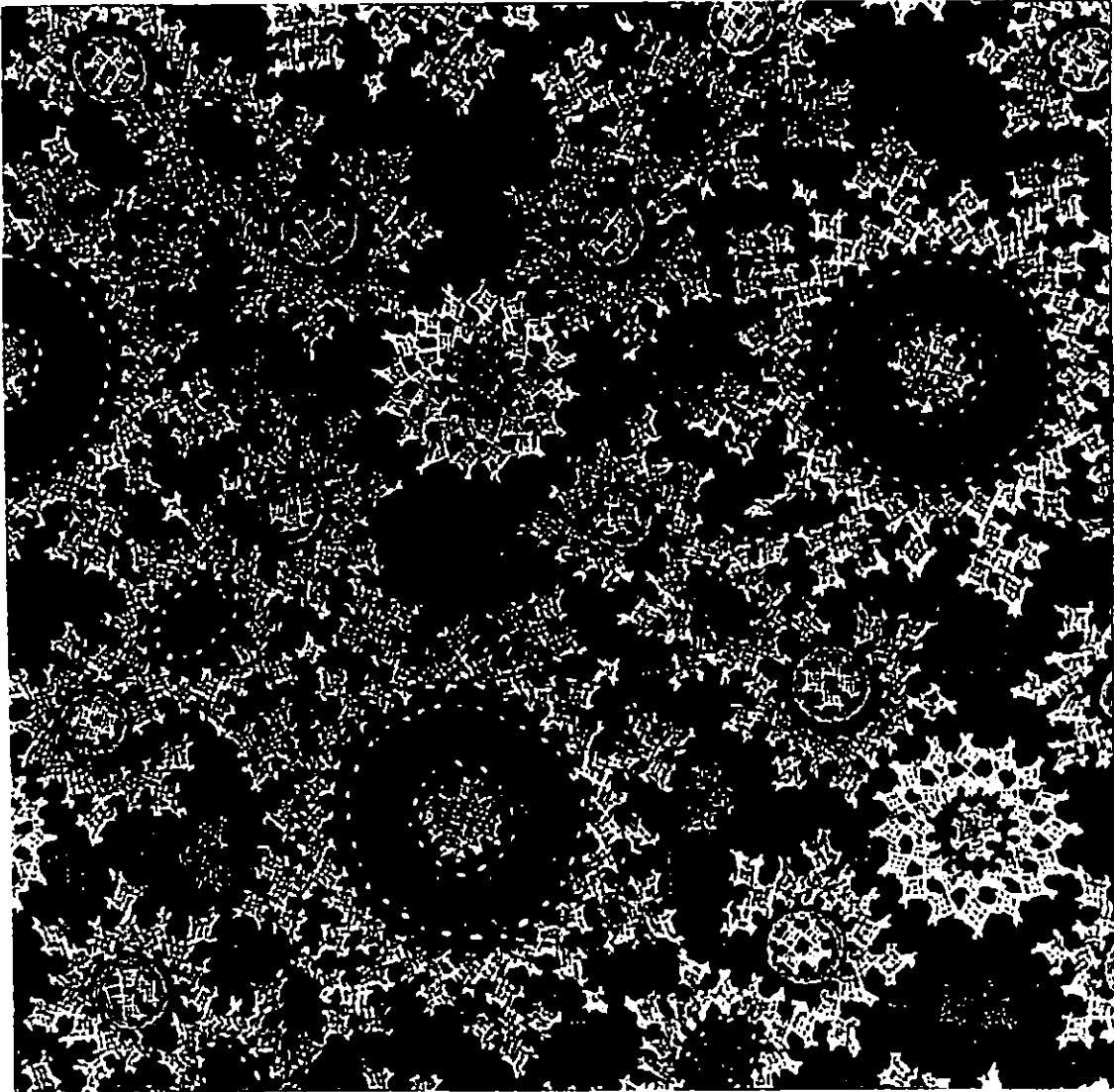

TEXTILE CONSERVATION NEWSLETTER



Number 21

FALL 1991

Recycled Paper



TEXTILE CONSERVATION NEWSLETTER

TABLE OF CONTENTS

FROM THE EDITORS	1
10 YEARS TCN S. Gail Niinimaa	2
THE CONSERVATION OF A SPLIT-HORN HEAD-DRESS Nicola Bushnell	3
THE DYNAMIC IMPACT OF RUBBER ON AMERICAN FOOTWEAR Louise Coffey	11
DESIGN AND CONSTRUCTION OF A STORAGE CONTAINER SUITABLE FOR A LARGE, FRAGILE GARMENT André Isabelle	13
INFESTATIONS PART II Julie Hughes	17
FIRE AT THE SASKATCHEWAN MUSEUM OF NATURAL HISTORY Don Pingert	20
NEWS FROM TEXTILE LABORATORY, CANADIAN CONSERVATION INSTITUTE	26
NEWS FROM THE McCORD MUSEUM OF CANADIAN HISTORY Eva Burnham	27
NEWS FROM GAIL NIINIMAA, PRIVATE CONSERVATOR	28
NEW PUBLICATIONS	28
BOOK AND EXHIBITION REVIEW: "BEVARANDETS HEMLIGHET - KONSTEN ATT VARDA, FORVARA OCH KONSERVRA" - "THE SECRET OF PRESERVATION REVEALED - THE ART OF CARE, STORAGE AND CONSERVATION" Gail Niinimaa	29
RESEARCH	31
FELLOWSHIP	31
CONFERENCE	32
EXHIBITIONS	33
TCN SUBSCRIPTION INFORMATION	34
TCN SUBMISSIONS	34

TCN
TEXTILE
CONSERVATION
NEWSLETTER



Number 21

FALL 1991

FROM THE EDITORS

The topics in TCN 21, Fall 91, are as diverse as ever. They include the treatment of a North American native headdress, the design of a container for a large fragile gown, procedures for monitoring and dealing with insect infestations, and the chronicling of what could have been a disastrous fire.

It has been 10 years now that Textile Conservation Newsletter has been in existence. Gail Niinimaa, one of its former editors, recaps the history of its development. TCN continues to be a not for profit newsletter written by and compiled for those in the textile profession. Its initial mandate has not changed. TCN publishes 2 issues each year as well as an annual supplementary. It has been indexed and now has an ISSN registration. In the 1989-90 subscription term, TCN had 175 subscribers - 100 personal and 75 institutional - in 22 countries. Articles have been published in

french and german along with their english translations.

An army of anonymous volunteers - specialists, colleagues, friends and family - has contributed to the planning, production, distribution and administration that is tied to TCN - collating, translating, proof reading, keeping the books, updating subscription lists, picking up and delivering things. TCN pays for word processing services, printing and postage with postage consuming most of the budget.

On behalf of all the subscribers, the editors wish to thank the volunteers as well as the contributors of TCN without whom there would not be a newsletter. The editors' job is a simply put it all together and send it to you.

10 Years TCN 10 Years TCN

The History of the Textile Conservation Newsletter-Canada, 1981-1991

At the IIC-CG (International Institute for Conservation - Canadian Group) meeting in Victoria, B.C. in May 1981 a group of 10 Textile Conservators and Specialists gathered to discuss the formation of a **TEXTILE CONSERVATION NEWSLETTER**. Present at the meeting were; Linda Suss, Helen Holt, Ela Keyserlingk, Sharon Little, Elizabeth Richards, Anne Lambert, Jane Batchellor, Marg Meikle, Betsy Johnson and Gail Sundstrom. The purpose of the newsletter would be to establish an informal communication network among Textile Conservators and Textile Specialists. Our publication dates were July 1 and Jan 1 and the editorship was to be split between East and West. Sharon Little and Gail Sundstrom volunteered to be the first editors. There was no charge initially for the newsletter as it was sent out from CCQ (Centre de Conservation du Québec) and all costs were assumed by the Ministère des Affaires Culturelles du Québec. Our initial mailout was to 65 people, many of whom were Textile Conservators or Specialists that we felt would be interested in the newsletter and who would contribute to it and support its existence.

The topics which were initially covered were: Supply Sources, Conservation Tips, Recent books or Articles of Interest, Upcoming meetings or Conferences, Upcoming Exhibitions on Textiles, Problems and Questions. We had 34 initial requests from Eastern Canada and a questionnaire was sent to 17 people in

Western Canada and as word of mouth continued to spread, we began to receive requests from the USA and Europe. At first there was an initial concern that we wouldn't be able to cope with all of the requests, but we just sent the a copy out to anyone who requested it and felt that if and when it became unmanageable we would deal with the problem at that time.

After our initial newsletter came out in Sept. 1981 we received about 20 letters of support and sincere congratulations from our colleagues in the field and we knew then that our newsletter would be successful.

At the IIC-CG meeting in Banff in 1983, another meeting was held to review the newsletter and by this time we had produced 4 newsletters and our requests had grown to 174. Abstracts of the Newsletter were being published in the AATA Abstracts. The publication dates were changed to Oct 15 and Mar 15 and the last issue to be published by CCQ was planned to be in March 1984.

It was stressed at the meeting that the Newsletter would only be as good as the material published and everyone was encouraged to submit articles. In March 1984 Gail (Sundstrom) Niinimaa and Sharon Little Ragusich retired after 6 issues and the editorship was continued by Colleen Wilson (West) and Eva Burnham and Julie (Crawley) Hughes (East).

The newsletter had become an effective tool and was reaching 203 individuals and institutions and was sent out to the USA, Europe, Latin America, Australia, and India. At this point the newsletter required membership to support it to keep it alive and a \$10.00 per year fee for two

issues was introduced. Single back issues were made available for \$3.00. What had started as an idea by 10 people had become a successful, informative and viable tool for the transfer of information about Textile Conservation in Canada and around the world.

Many volunteer hours have been and still are committed to the success of the newsletter and Eva Burnham in particular has been the force behind it since 1984. Although it has changed somewhat since it's initial issues, the spirit of the Newsletter remains the same and it is still a viable tool for communicating and sharing information. As a former editor, I would like to congratulate Eva Burnham and Ruth Mills for their excellent work and the dedication that they have shown in keeping the issues coming out. As many of our membership would agree, I always look forward to receiving my copy in the mail and hope that the **TEXTILE CONSERVATION NEWSLETTER** can sustain itself for another 10 years.

S. Gail (Sundstrom) Niinimaa
Former Editor
**TEXTILE CONSERVATION
NEWSLETTER**

THE CONSERVATION OF A SPLIT-HORN HEAD-DRESS

Introduction

A split-horn head-dress from the Scriver Blackfoot Collection of the Provincial Museum of Alberta, Edmonton, (Accession No. H89.220.183) is being conserved at the Canadian Conservation Institute (CCI).

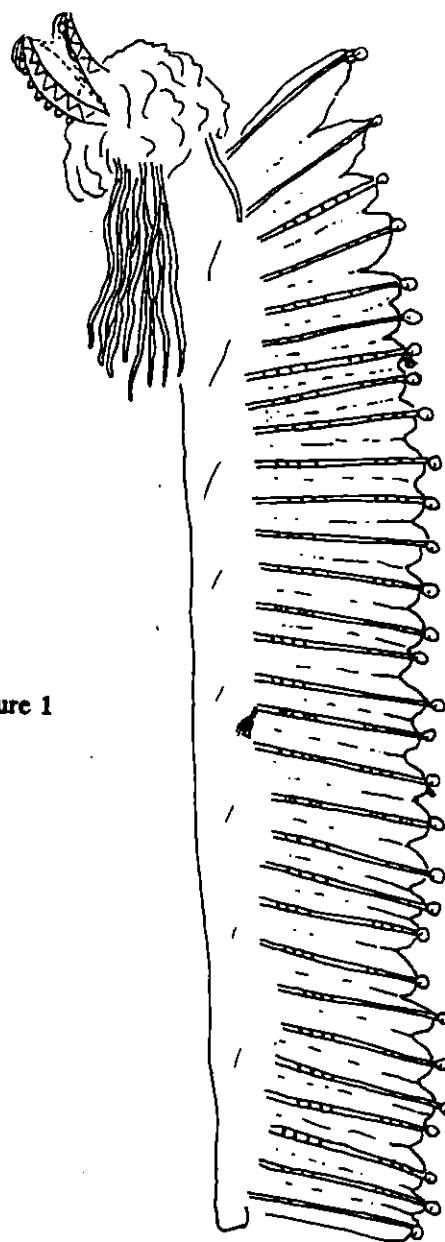

Figure 1

This head-dress (Figure 1), of circa 1850, is attributed to the Horn Society of the Blood Tribe. The Blood, Peigan and Blackfoot tribes collectively form the Blackfoot Nation of Plains Indians who live in southern Alberta and northern Montana. It is possibly the head-dress which was worn by one of the two male leaders of the Horn Society for ceremonial purposes (Wissler, 1913: 411).

The Horn Society was a secret society; a person had to be initiated into it. As with all secret societies, particular rites, traditions and sacred objects were associated with it. According to Wissler (1913: 411) the members of the Horn Society were regarded as very powerful; even to talk about them was considered dangerous. Usually both husbands and wives were members with the men owning the society medicine bundle which contained the costume and ritual objects needed for the dances and ceremonies.

The sacred objects of the Scriver Collection are important to the Blackfoot people. Part of the Provincial Museum of Alberta's policy for the treatment of sacred objects is that no menstruating woman should touch them as the Blackfoot believe this to be dangerous for both the woman and the object. This policy and the usual conservation ethics were observed throughout the treatment of this head-dress.

Description

The head-dress consists of a horned cap and a single trailer joined together by semi-tanned leather thongs and two wooden bars. The overall length is 175cm with the greatest width 26cm and the

narrowest section 16cm. The cap is composed of striped cotton cloth, white curly fur and pieces of weasel skin. Weasel skins with tails and ribbons of six different colours are attached at both sides. The front has a red cloth brow band with brass buttons. To the top of the cap are affixed two simulated horns, probably of wood covered with hide. These are wrapped with green and white ribbons. Small red and white glass beads are strung between the tips of the horns and the crown of the cap. Brass bells are strung along the horns, and semi-tanned skin and strips of weasel skin hang from the horn tips. The rawhide trailer is covered with red woollen blanket cloth and thirty golden eagle tail feathers are attached to it by means of a semi-tanned leather thong which runs through the eagle feather quills at the back of the trailer. Strips of rawhide wrapped with both dyed and undyed porcupine quills and coloured wool are attached to the feathers by sinew. Brass bells hang from the top of the rawhide and small dyed and undyed feathers are attached near the base.

Analysis

When the object arrived for conservation it was dusty and had signs of past insect damage with old insect cases. The weasel skins were yellowed, brittle and stained with dye. Two of the black weasel tails were torn and losing hair. All the ribbons, except the red, were extremely degraded and tattered. The blanket had a few small holes and was stained yellow in one area. Some quill-work was unravelled and discoloured and one brass bell had an area of green corrosion on it. All the eagle feathers, except the base of the end one, which was a replacement, were very

yellowed and extensively dislocated with some barbs broken and missing. The front of the head-band had an area of staining.

The information accompanying the head-dress was that it had been collected during the 1960's and stored, rolled in a rawhide bag with Bull Durham tobacco and moth-balls (naphthalene). When the museum received the head-dress in 1989 it was vacuum cleaned and placed on display for approximately four months.

Even though there was no record of arsenic or mercuric chloride ever having been used on the object it was decided to test for both these substances before commencing treatment (Appendix 1). Both tests proved negative.

A few fibres of the different collagenous materials were taken and the shrinkage temperatures obtained using a Leitz PCC 2-6022 polarizing microscope and a Mettler FP 82 hot stage. These all proved to be very low, indicating that the collagen was degraded and potentially readily damaged by any treatment involving water.

Small samples were taken from the different ribbons and the fibres identified using a Leitz PCC 2-6022 polarizing microscope (x10) and known standards. Some ribbons had cotton wefts with silk warps whilst others were silk with only extra cotton warps in the selvages for reinforcement.

Small samples of the ribbons were placed in tap water at room temperature in separate small glass vials with screw tops, to check for dye fastness. Within ten minutes the orange, red and the wide cream coloured ribbons proved to have

fugitive dyes and within five hours the burgundy colour also proved to be fugitive.

Tobacco and white crystals were still in evidence in the thick fur of the cap so samples of the white crystals were taken for analysis. Tests in the laboratory showed the crystals to have a pH of between 8.5 - 10.0 and to be soluble in both water and mineral spirits. The crystals were identified as sodium borate hydrate (borax pentahydrate) using X-ray diffractometry with a low background sample holder over the full range of angles in a six minute period (Sirois, ARS No. 2976). These crystals had probably been applied to prevent insect damage but because of its high pH value when exposed to water any remaining crystals were removed as far as possible using a hand held mini vacuum cleaner.

Small samples of both yellowed and unyellowed feathers were taken and examined using the microscope (x10), the Scanning Electron Microscope with X-ray Energy Spectrometry (SEM/XES) and finally using Fourier transform infrared spectroscopy (Moffatt, CCI ARS No. 2970). The last analysis showed the spectra to be almost identical for both the yellowed and unyellowed feathers and there to be no coating present.

Treatment

Both the green and white ribbons on the horns had cotton wefts and selvages. Most of the silk warp had degraded and no longer existed. Where the ribbon selvages were intact the cotton wefts lay in loose wavy lines from selvedge to selvedge, no longer held in place by the warps. Where the selvedge was not intact

the cotton weft had unravelled and become a long strand of cotton. In some cases this had been wrapped loosely round the horn. The wavy cotton threads were couched onto the underlying fabric of the horns using a curved needle and dyed hair silk. Where possible the loose strands were reformed into the configuration of weft threads and couched into this position.

As the ribbons hanging from the sides of the cap were so degraded the decision was made, on the advice of Eva Burnham of CCI, to encase rather than back them. This would avoid both the use of adhesives and unnecessary stress to the ribbon by extensive couching. Silk crêpeline ribbon and hair silk were dyed to match the colours of the degraded ribbons using Ciba Geigy Irgalan dyes and an Atlas LHTP dyeing machine.

Each degraded ribbon was straightened prior to being encased. A compressed wood fibre board (Tentest) with a grid pattern marked on it and covered in polyethylene film was placed in a slanted position close to the cap. The cap was covered with Mylar (polyester film) and each ribbon to be straightened was pinned approximately one inch away from the cap, using Grade 000 nylon headed entomological pins. The ribbon was then sprayed with tap water, taking care not to let the water wick up the ribbon to the cap. While wet the ribbon was straightened and any loose threads aligned. It was then blotted with Whatman No 1 filter paper. Entomological pins were used to pin the ribbon straight and warm air was blown from an air blower to aid drying.

The new silk crêpeline ribbon has a shiny

thread running down both edges. This was removed by cutting small sections and slipping it out with the aid of tweezers. When the new silk ribbon was only slightly wider than the original ribbon the case was formed by cutting a length of the dyed ribbon twice the length of the original and folding it in half across its width. A straight needle and dyed hair silk was used to sew a running stitch along one side of the folded ribbon. The degraded ribbon was then placed between the two layers of new ribbon and pinned onto the board. The other side of the new ribbon was then sewn with hair silk and a running stitch using a small curved needle. Three rows of running stitch were sewn across the encased ribbon near the cap to prevent the casing slipping off.

Where the new silk ribbon was appreciably wider than the original, the new ribbon was folded to the required width and ironed along the fold. A straight needle with dyed hair silk was used to whip stitch over the fold (Figure 2). The fold was then pressed open and most of the excess material cut away (Figure 3). The fold was then pressed in place again (Figure 4). The casing was then formed by folding the ribbon as before but this time whip stitching the new edge. The second edge was sewn with a running stitch as usual (Figure 5).

Loose and unravelled cotton threads from the ribbons were wrapped round stiff Mylar cut to the width of the same coloured ribbon. They were then sprayed with tap water and placed between filter paper with a weight placed on top. The thread dried to the shape of the ribbon

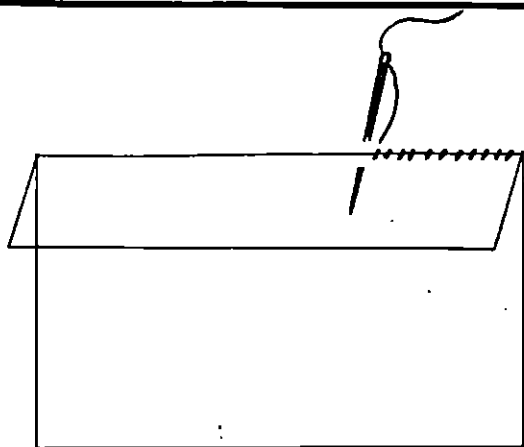

Figure 2

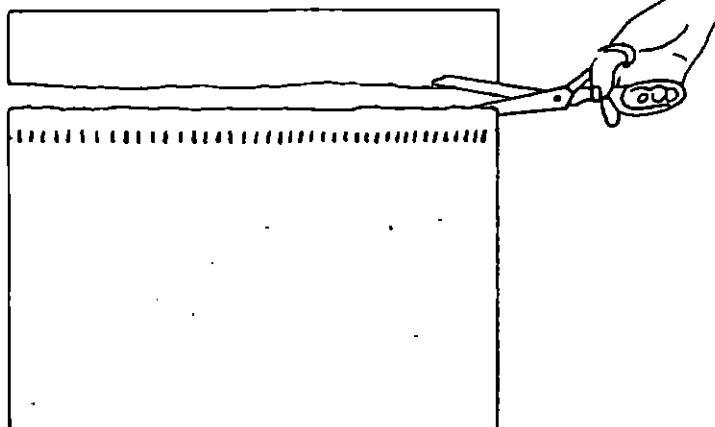

Figure 3

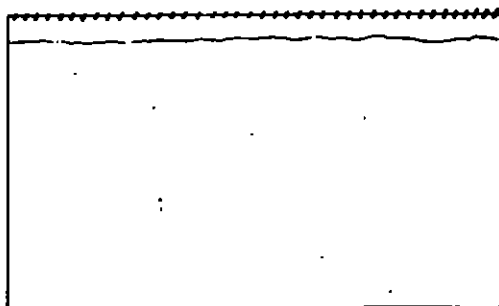

Figure 4

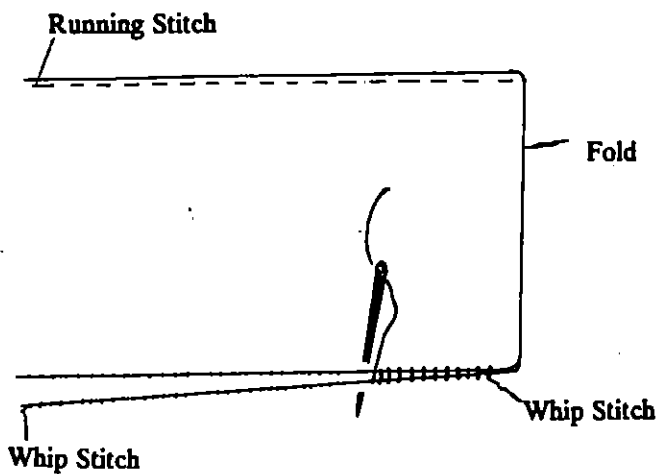

Figure 5

and this formed piece was placed at the end of the degraded ribbon when it was sewn into its new case. Where the original ribbon was degraded near the cap it was encased as before and the holding stitches for the casing sewn through a stronger ribbon behind it.

In the two places where the weasel skin was torn, and the tail section likely to come away, a backing of reformed collagen membrane was attached using the acrylic emulsion Lascaux 360 HV. The black tip of the tail was tied with dyed hair silk in an effort to prevent further hair loss.

The stain on the cloth head-band appeared green under the microscope (x10) but when it was analyzed using X-ray diffractometry, SEM/XES and Fourier transform infrared spectroscopy the components discernable were calcium carbonate, chlorine, potassium and sulphur (probably from the cloth) (Sirois, CCI ARS No. 3003). The stain was not removed in case it was the residue of an intentional application.

The feathers did not respond to cleaning with absorbent cotton swabs dampened with either distilled water or ethanol so they were brushed gently with a small paintbrush to remove any loose dust and to align the barbs where possible. Loose quills were tucked back into place or secured where necessary with Lascaux 360 HV adhesive.

Backing was considered unnecessary for the small holes in the blanket. Two separate samples of corrosion on the bell were tested for chlorides (Appendix 2). The result proved positive in both cases and the corrosion was removed with

ethanol. Further evidence of corrosion was visible on the cloth covering the back of the buttons on the head-band. This corrosion was not removed as access was impossible without dismantling the cap.

A storage box is being constructed from Hi-Core (polycarbonate sheets) in the manner described in the **TEXTILE CONSERVATION NEWSLETTER** Number 20 (20:21-26) by Carl Schlichting.

Silk ribbon is obtainable from:
Bally Band AG
Band und Etikettenfabrik
Schachenstrasse 24
CH-5012 Schönenwerd
Switzerland

Appendix 1

Originally from handout printed by Carnegie Museum of Natural History, 5800 Baum Boulevard, Pittsburgh, PA 15206

Test kit developed by Stephen Weber. Dept. of Chemistry, University of Pittsburgh.

Test for Mercuric Chloride

Reagents

50/50 mixture of ethanol and water
Phenylazofornic acid (2-phenylhydrazide, suitable for colorimetric analysis)

Procedure

An approximate 1% solution of 2-phenylhydrazide in 100ml of the distilled water and ethanol mixture was made up by placing a spatula tip quantity of the chemical in a test tube and adding approximately 4ml of the ethanol and water mixture. The test tube was heated in a beaker of hot water and shaken until the chemical had dissolved. The solution was then added to the remaining ethanol and water mixture. The reagent was a pale amber colour.

This test is primarily for mercuric chloride in powder or crystalline form but two absorbent cotton swabs dampened with distilled water were rolled over an area of fur and an area of one of the eagle feathers. The swabs were allowed to air dry at room temperature over night and then tested with the phenylazoformic acid solution. No colour change was observed therefore no positive result was obtained for the presence of mercuric chloride.

A positive control experiment was also carried out using mercuric chloride crystals. The solution turned a deep magenta colour.

To investigate the sensitivity of the phenylazoformic acid solution test a further experiment was carried out using an absorbent cotton swab which had been dipped in a very dilute solution of mercuric chloride. The swab was allowed to dry out over night and then phenylazoformic acid solution applied. The test proved to be very sensitive as a positive result was obtained indicated by a deep magenta colour.

Test for Arsenic

Test kit developed by Stephen Weber,

Dept. of Chemistry, University of Pittsburgh.

Equipment

Small test tubes and stand
Pipettes
Small flask
Spatula
Absorbent cotton
No. 1 Qualitative filter paper

Chemicals

Cuprous chloride
Zinc dust (non-arsenical)
1M Potassium hydroxide
3M Hydrochloric acid
0.1N Silver nitrate
Distilled water

Procedure

Absorbent cotton swabs dampened with distilled water were rolled over areas of fur and feathers and collected in separate beakers. The swabs were allowed to air dry at room temperature over night in a fume cupboard.

Approximately 1/4 tsp. of cuprous chloride was placed in a small flask and 5-10ml of distilled water was added. The flask was shaken until most of the cuprous chloride dissolved.

Each of the swabs to be tested was placed in a separate test tube and two drops of 1M potassium hydroxide was added to each to dissolve the sample.

A little zinc dust was added, followed by a few drops of 3M hydrochloric acid until effervescence began.

A loosely packed wad of absorbent cotton was placed halfway down the test tubes and a few drops of cuprous chloride solution was added around the edge of the absorbent cotton.

A piece of No. 1 filter paper was placed over the top of each test tube and 1 or 2 drops of silver nitrate solution placed on the filter paper.

No colour change was observed for any of the samples.

A positive control experiment was carried out at the same time using a 1000ppm arsenical compound. The presence of arsenic was indicated by the silver nitrate solution on the filter paper turning dark grey/brown in colour.

A negative control of distilled water was also carried out.

To investigate the sensitivity of the test for arsenic a further experiment was carried out. An absorbent cotton swab was dipped in a very dilute solution of the arsenical compound. This swab was allowed to dry overnight and the test for arsenic performed as above. A positive result was again obtained proving the test to be very sensitive.

Appendix 2

Test for Chloride ions (Plenderleith and Werner, 1971: 200-201)

The sample was dissolved in a few drops of distilled water. The dissolved sample was then acidified with 5% nitric acid

until a pH of 5 was reached. Two drops of 5%w/v silver nitrate was added.

Result: A white precipitate of silver chloride was formed.

A negative control was run at the same time using distilled water.

Result: No precipitate was formed.

References

Moffatt, Elizabeth. (1991). Analysis of Feathers from a Split-Horn Head-Dress, C.C.I. Analytical Report ARS No. 2970. Unpublished report.

Sirois, Jane. (1991). Analysis of White Crystals Present on a Feather Head-Dress, C.C.I. Analytical Report ARS No. 2976. Unpublished report.

Sirois, Jane. (1991). Analysis of Green Accretion on Split-Horn Head-Dress, C.C.I. Analytical Report ARS No. 3003. Unpublished report.

Bibliography

Plenderleith, H. J., and Werner, A. E. A., (1971) The Conservation of Antiquities and Works of Art, 2nd Ed., London, Oxford University Press.

Wissler, Clark (1913). Societies and dance associations of the Plains Indians. Anthropological Papers of The American Museum of Natural History, Vol. 11, Pt. 4.

Nicola Bushnell
Ethnology Intern
(Funded by The Conservation Unit of The
Museums & Galleries Commission,
London, England)
Canadian Conservation Institute
Ottawa, Ontario.

LADIES' SARATOGA.



With full cape and sleeves; cape to button in front.

LADIES' ULSTER.



A very stylish garment, to be worn with the present style of close-fitting costumes.

See that they are stamped on loop, "Man'd by Gossamer Rubber Clothing Co." Boston, U. S. A.

1882

THE DYNAMIC IMPACT OF RUBBER ON AMERICAN FOOTWEAR

(Excerpts from the presentation given at the Costume Society of America's Annual Symposium in Boston, May 1991.)

Why has rubber had such a dynamic impact? It is a unique and natural resource. It is elastic, plastic and waterproof, and is indigenous only to the tropical Americas. It has affected our lives enormously: our methods of transport, our treatment of health and our dress. Of our dress, it has probably affected our footwear most of all.

The history of rubber is longer than one might expect, and people of the Amazon were making rubber shoes long before the coming of the Europeans. As early as 1495, rubber production was observed by the men of Columbus' second expedition to the Caribbean. Rubber first came to Europe in 1735, brought by some French astronomers, who were sent to Brazil to

make astronomical observations.

Rubber lends itself well to romantic adventure stories, though not all of them are true. Sir Henry Wickham did not secretly smuggle rubber tree seeds from the *Hevea Brasiliensis*, purportedly for the Queen's garden, but legally despatched them to the Royal Botanical Gardens at Kew for propagation in 1876. It's just that no-one else had thought of growing rubber elsewhere in the world. Of Wickham's seeds, 2,000 seedlings were later shipped to Ceylon, a huge producer of rubber today.

In 1820 the first India rubber shoe was shipped from Brazil to the US, but after the initial excitement, the reception was poor. In warm weather the rubber became soft, sticky and smelled bad, and in winter it would be brittle and stiff.

How was the rubber obtained? The sixty-foot rubber trees were cut and tapped for the milky white latex. This is not the sap, which runs deeper in the tree trunk. The cups were poured into larger vessels and taken to be coagulated by smoking. The fire was made from the nuts of the Wasson palm tree and confined in a clay chimney through which the smoke emitted. The latex was then poured onto a type of paddle and constantly turned to harden the rubber, which also darkened it. From here on, the steps in rubber footwear production are: washing and cleaning the rubber; drying; compounding (which is kneading the rubber with other ingredients); calendering (which is passing it through rollers to coat fabric and impress a pattern); cutting the parts (in 1912 a rubber shoe comprised 21 different pieces - and boots even more than that); and putting the parts together, usually by

cementing. Then varnishing gives rubber its glossy look, and finally, while still on the last, the footwear is vulcanized.

What is vulcanization and why was it so important? Although the first patents for rubberizing canvas and leather were taken out as early as the 1790's, it wasn't until the late 1840's that American rubber footwear was developed after Charles Goodyear had invented Vulcanization in 1839. For years people had been experimenting with ways to harden rubber consistently, and there are many accounts of scientific espionage relating the competitive nature of this adventure. In America, it was a Massachusetts man Nathaniel Hayward who discovered the magic of sulphur, and Goodyear who recognized the essential element of heat to alchemize the product. The patent of February 24th 1839 went to Nathaniel Hayward, Assigner to Charles Goodyear. The process was named after the god of fire, Vulcan, since temperatures had to reach 260° F for successful processing. Today the name Goodyear is associated with rubber tires, but initially it was associated with rubber footwear. In fact, if you look at a Goodyear sign today, the logo of Mercury's winged footwear called "talaria" is still in existence.

Organized sports came to fruition in the late 19th century-According to Colin McDowell, the first customized sports shoe (laced canvas upper and rubber sole) was designed for croquet in the 1860's. Previously, a patent had been granted to a New Yorker, Wait Webster, for the attachment of rubber soles.

Rubber storage is a challenge since the rubber deteriorates irreversibly.

When oxidation occurs, it is noticeable as either tackiness or brittleness, basically due to the way the rubber molecule's carbon-carbon bonds either breaking or linking together.

Pure rubber footwear is only likely to exist before WWI. Thereafter, any manner of compounds or fillers may have been used in production, and synthetic rubbers may not react in the same way.

The usual conditions apply for storing costume: away from light, keep cool (preferably 49°F/9°C), avoid temperature and humidity fluctuations (about 50 %RH), and keep in a pollutant free environment, especially free from ozone. And where possible, rubber should be isolated from contact with metal. Oxidation increases at higher temperatures. If the rubber is slightly tacky, use mylar, or at least glassine rather than acid-free tissue as a barrier. If you are certain that the rubber is stable enough for tissue, use only unbuffered. Also, beware of using white cotton gloves in case the fibers stick to rubber. In 1988 Mitsubishi Gas Chemicals came out with a product called "Ageless Oxygen Absorber" and the Canadian Conservation Institute has been using it and liking it so far.

Numbering can be tricky. One method would be to use a barrier such as butylmetacrylic, but please don't attempt this without a conservator or scientist at hand to analyze the rubber content. A safer bet would be to use gouache, a water-based paint, to paint on the number. For further reading I recommend Sharon D. Blank's "Rubber in Museums: A Conservation Problem" (1986) and David W. Grattan's "The Problem of Rubber

Conservation" presented at the Harpers Ferry Regional Textile Group in Washington, D.C., 1988. Both have excellent bibliographies.

Louise Coffey
Collections Manager
History Division
Natural History Museum of
Los Angeles County

DESIGN AND CONSTRUCTION OF A STORAGE CONTAINER SUITABLE FOR A LARGE, FRAGILE GARMENT

How do you pack garments for storage that are so fragile and delicate that even the slightest handling would damage the fibres and tear the fabric? Such is the condition of some of the garments that we occasionally have to prepare for storage at the Canadian Parks Service in Ottawa.

Normally our garments and textiles are stored in regular cardboard containers lined with acid-free paper. Because of our restricted space, the size of our regular textile containers are 24" x 36" x 6". Occasionally certain garments have to be stored in larger containers due to their size or fragile and damaged condition.

Here is an example of the process used to design and construct a container for such a garment. The garment was a large, fragile, valuable, silk robe.

The problem:

The robe was too large to fit into our regular textile containers. It was too fragile to be handled or folded even with

careful padding of the folds to fit our standard size of container. It was heavy and fragile and would cause damage to itself by its own weight. It required air circulation. It also needed to be shipped to its permanent location.

The design of the container:

The storage container was to be large enough to prevent unnecessary folding of the robe, trying to retain its natural shape as much as possible without putting strain on the fabric. The robe was so fragile that it was decided to mount it on a padded form and suspend it inside its storage container in a horizontal position. The mounting form would rest on inside supports and would hold the form firmly without the robe touching the bottom, top or sides of the container. The container would be made of inexpensive and readily available materials. It would be made in two parts, a deep bottom and a flat lid that was completely separate from the bottom. Because the finished size required for the container was known only after the robe was mounted onto the mounting form, it and its cover would be built after the robe was mounted on the form.

Mount and mounting:

A mounting form in the general shape of the robe was built with extensions at both ends approximately 8" long to allow for mounting inside the container. These extensions also were used as handles to move the robe when required without actually touching the garment. To build the mounting form we used a piece of wood 3/4" thick by approximately 7' long and fastened (with Monel rustproof staples) a piece of bell shaped Tri-wall (triple layer laminated cardboard), 6' long that measured approximately 30" wide at

the bottom (skirt) and tapered in to approximately 18" wide at the top (shoulder), onto the piece of wood.

Mylar was wrapped around the form to seal it and protect the garment from the very acidic wood and cardboard used. This was also stapled in place using Monel staples. Polyester fibre fill was then used to build up the form to the dimensions of the robe and the fibre fill was covered with washed unbleached cotton.

To mount the robe, the form was placed on blocks high enough to allow working around it. The robe was mounted around the padded form. It was wrapped with cotton covers which held the robe securely to the padded form. This step was done by the textile conservator and is not described in adequate detail here.

The container (Illustration 1):

Now that the robe was mounted and the final dimensions were known, it was possible to measure for and construct the container. Enough space was left around the robe to allow for air circulation and the inside protective layers of the container. A finished space of approximately 2" was allowed for air circulation all around the robe. At the time, wood and cardboard were the only materials available to us. The walls of the container were made of Tri-wall with 2" x 2" cedar strips used on the outside to give the container a strong frame. Tri-wall is easy to work with and light weight making the finished container as light as possible.

The container was lined with a fibre board 1/2" thick and then the inside of the container was covered with heavy duty acid free paper (library endleaf). Air

holes, 1" in diameter, were drilled approximately 18" apart around the container and were covered with a light screen on the inside to keep dust out of the container. Inside the container, a support was installed at each end to suspend the form and prevent the robe from resting on the bottom of the container. Two small boards were fastened in place on pins to lock the form in place and prevent it from moving (Illustration 2).

The cover was constructed in the same manner and was also lined with the same materials as the bottom of the container. The cover was fastened to the bottom with butterfly closures.

The robe was then mounted in the container, fastened in place and was ready for delivery. The container was well packed and sturdy enough for handling by trained personnel but because of its value and fragile nature, we could not take a chance with commercial freight carriers.

Comments:

This container was built approximately 6 years ago, the materials used were acceptable at the time but if we were going to pack a similar artifact today, the methods and materials used would be quite different. This exercise was one of the projects that prompted us to find other materials that would be suitable for artifacts. We are always looking for better materials and designs for our containers, to make them less expensive to build and safer for the artifacts. Since then we have designed and have had Coroplast (corrugated plastic) boxes manufactured locally. We have been able, through trial and error, to build our own Coroplast

containers (See TCN "Corrugated Polypropylene Containers": 18:2-6). Although plastics are not easily recycled we feel that, by constructing plastic containers that can be reused several times we are helping the environment by not creating as much non-recyclable refuse and by reducing our usage of paper products.

André Isabelle
Head Custodian,
Interpretation Branch
National Historic Sites Directorate
Canadian Parks Service
2630 Sheffield Road
Ottawa, Ontario
K1A 0H3

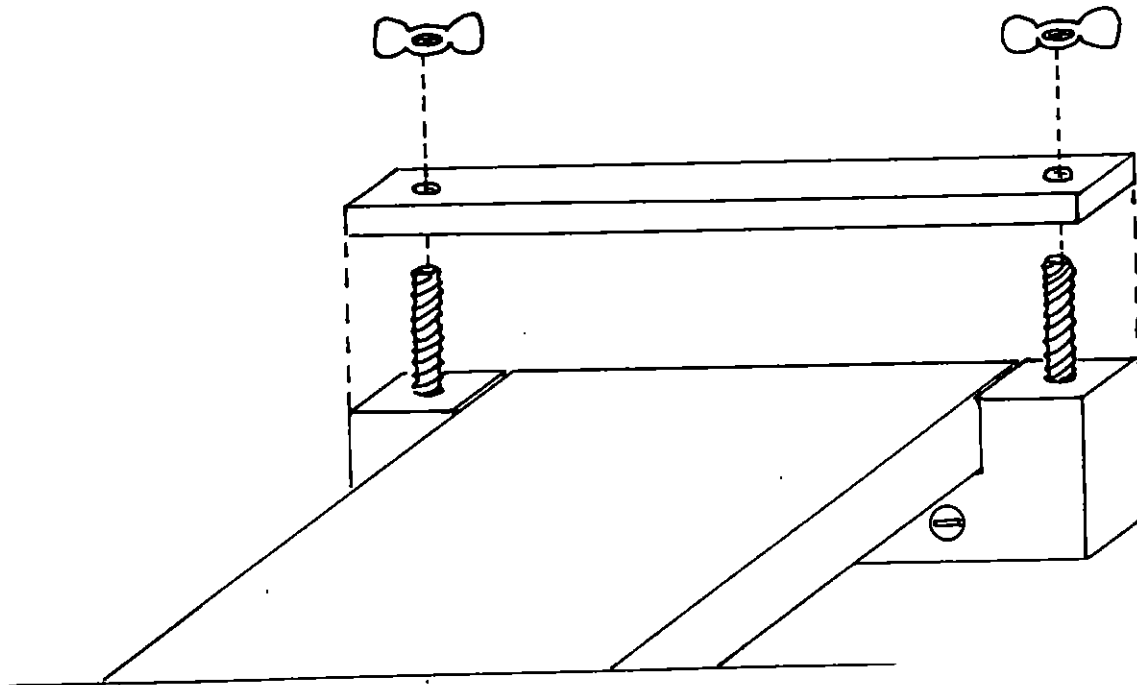

Illustration 2

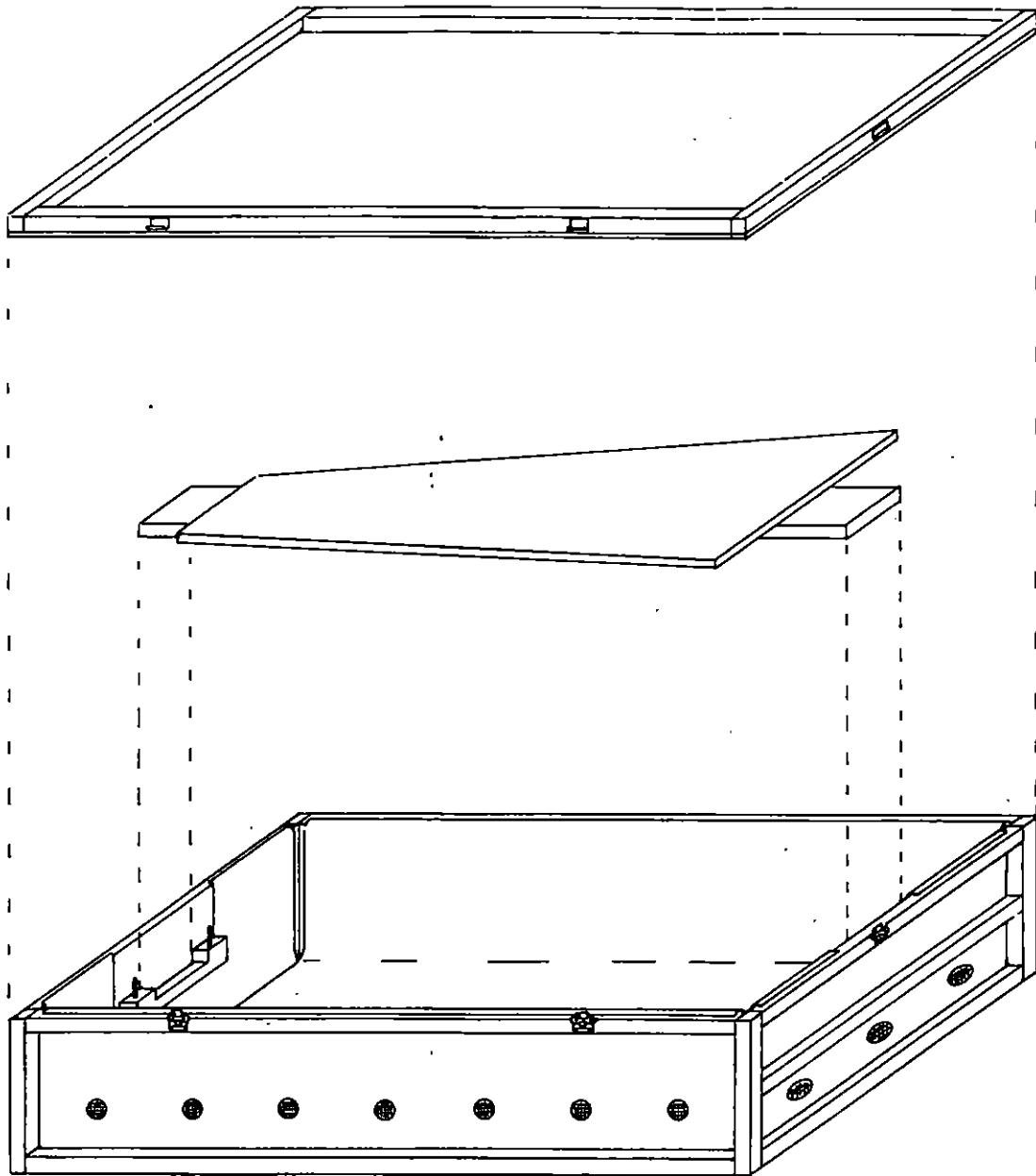
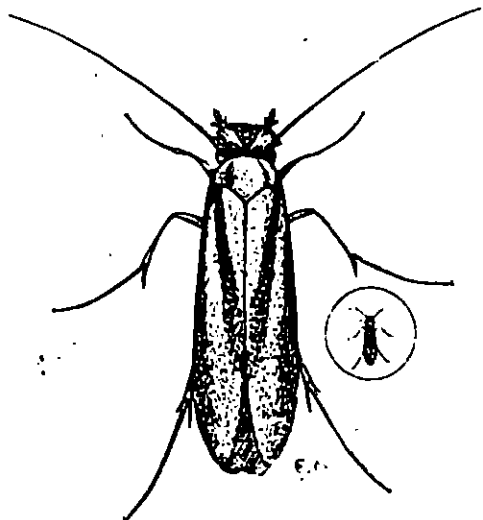

Illustration 1



The webbing clothes moth, enlarged and natural size (original)
Department of Agriculture, Ottawa, 1929

INFESTATIONS PART II

As mentioned in the Fall 1990 issue of TCN (19:11), the Textiles Laboratory of the Canadian Museum of Civilization has had numerous occasions to deal with infestations. We promised a full explanation of our procedures for the surveillance of our collections, and for the treatment of infested textiles.

(No submission was prepared for the spring 1991 issue owing to the absence of Julie Hughes, on maternity leave.) They are as follows:

A) "Moth" Check Procedures

The importance of maintaining regular checks of storage and appropriate exhibit areas for infestations cannot be overemphasized. All locations should be scheduled for checks on a rotating basis so that they all receive regular inspections. A tremendous amount of unnecessary

work can be avoided if a problem is detected at its initial stage. Good housekeeping in storage areas - good air circulation, environmental controls, cleanliness, limited access of personnel, no admittance of food or drinks, etc. - are primary essentials to help prevent problems from developing.

Although cursory checks for insect problems, by simply opening drawers (for example) and quickly looking through, might reveal insect activity, a complete examination of all textiles is required periodically in order to do the job thoroughly. (We include vacuuming and repadding at the same time.) Our aim is to accommodate the "thorough" approach, while maintaining general surveillance on all our collections holding areas. This is done by scheduling a check of one storage area per week (one half day, with two people). In each location, with each visit, one cabinet of drawers (for example) is gone through completely. Each textile is taken out, old tissue is removed, the piece is inspected inside and out, vacuumed, the drawer is relined with new tissue or microfoam, and the textile is put back into the drawer and repadded with clean tissue or microfoam. (Naturally allowances must be made for fragile textiles which would suffer more harm than good from this periodic handling.) As much of the one unit (eg. cabinet) is done as time permits, leaving enough time to give the entire location a "cursory" visual inspection for any sign of insect activity. This system also provides that all textiles in storage get repositioned -eg. folds changed, etc. - at least once every so often (depending on size of collection).

A log-book is maintained to record the action taken during each visit (as well as

to note any other problems requiring attention) so that the next team knows where the work was left off.

We have also found it useful to install a colour-code system on storage units. These are simply small red, yellow and green adhesive-backed dots which we stick onto the appropriate place - eg. the exterior, corner of the front of a drawer. A red dot indicates that the drawer contains a textile composed of materials more vulnerable to insects - wool, feathers, etc. This aids in rapid detection of the possible source of the problem, should an infestation be discovered. A yellow dot cautions that the contents of the drawer are very fragile and that the drawer should only be opened, when necessary, very carefully. A green dot denotes that the textile is in need of conservation attention. Details, priorities, etc. are recorded in the log-book, and action is taken according to the workload priorities of the lab, and in consultation with the Division to which the textile belongs.

B) Infestation Procedures

Should an infestation be discovered, the action below is taken. Freezing is the technique favoured at present by our Division, for the eradication of insect infestation, as it is deemed the safest effective procedure for both artifact and handler. The procedure described is based on recommendations contained in the references given at the end of this section, especially the first reference by Mary-Lou Florian.

1. Identify Insect

A sample insect is collected into a small

glass vial for identification purposes. Our local source of expertise for this purpose is Agriculture Canada, Neatby Bldg, Carling Ave., contact José Poirier at 996-1665, extension 7309 (Room 3119). (While identification is being done, proceed with bagging immediately.)

2. Bag and Label Textile

The infested textile is bagged in 8 ml clear polyethylene film. Depending on the textile, it may need to be folded to fit into the freezer (no tissue is used to support folds in this case). Try to squeeze out as much air as possible where appropriate considering the textile, before sealing the bag. The plastic is sealed using any brand of 2" wide clear packing tape (eg. 3M "Highland Tape 371"). Although masking tape will stick to a flat piece of plastic, it doesn't hold very well on folded edges. A heat-sealer can also be used if appropriate, or the edges of the plastic can be folded several times and stapled (although this is not a preferred method - risk to textile getting caught - staples being removed & getting lost, etc.)

The textile's accession number, and the date the textile is bagged, is written onto a piece of masking tape with a Staedler indelible pen, and stuck onto the outside of the bag.

A separate log-book is maintained of the dates of entry and removal of textiles from the freezer.

3. Determine Extent of Infestation

As soon as the infested textile is bagged, a check is made to determine the extent of the infestation. (If it is immediately obvious that numerous textiles are

involved, team-work is begun - some working on bagging and others doing the check.) Based on the insect discovered, those materials prone to attack are examined first.

4. Freeze textile

The bagged textile(s) is/are placed into the freezer as soon as possible following discovery of the infestation. If the quantity of textiles affected is more than can be accommodated in the freezer at one time, they are left at room temperature until space becomes available. It is important that the insect be exposed to a rapid drop in temperature for the procedure to succeed. If the rate of drop is too slow, the insect may shed body water (called "purging") thereby increasing its fat content and enter a dormant state in which it could survive the freezing process.

We have two freezing units available. One is a regular household chest freezer from Sears (which freezes to below -20 C) and the other is a VIRTIS Model 36DX66 freeze-dryer. Either one is used (for freezing only) depending on the space required, and other objects which might already be inside. The racks in both units allow spacing of the textiles to provide good air circulation. The textile is left in the freezer (at -20 C) for a minimum of 48 hours.

5. Remove Textile from Freezer and Thaw, Still Bagged

Following freezing, the textiles are brought out and left to thaw completely, still bagged. (Logistics have not made it possible for us to place them in a refrigerator to thaw, although this is

recommended - see reference #1. It has also not proven possible, owing to the quantity of materials we have dealt with in the past, to repeat the freeze/thaw cycle. Surveillance after the one freezing cycle has verified the effectiveness of the procedure.)

6. Prepare Textile for Storage

Depending on the circumstances, the textile might or might not be left in the plastic for storage. It would be left in plastic if this presented no problem to the piece, and there still existed some doubt as to the efficacy of the freezing process. Usually, when completely thawed, the textile is removed from the plastic, thoroughly vacuumed using disposable vacuum bags (deposited in receptacles outside the building), and prepared for storage. (In some instances we might also dry or wet clean the textile, if deemed necessary.)

7. Record Action Taken

A report of all action taken is provided to the file for the individual textile. If numerous textiles have been involved, a generic treatment report can be written for all of them, leaving the accession number blank; xeroxes can be made, and then the number filled in afterward for each.

CMC staff of other divisions, especially those working directly with collections, are advised first to note the location of a suspected infested artifact, and to contact us immediately. Illustrations of insects which pose the greatest threat to objects are posted throughout our various Collections Holding areas.

References

1. Mary-Lou Florian

"The Effect on Artifact Materials of the Fumigant Ethylene Oxide and Freezing used in Insect Control" (Preprints of the 8th Triennial Meeting of the ICOM Committee for Conservation, held in Sydney, Australia, 6-11 September, 1987)

2. Mary-Lou Florian

"Methodology in Insect Pest Surveys in Museum Buildings - A Case History" (Preprints - same as #1)

3. Mary-Lou Florian

Draft of "Effects of Standard Museum Preparation Methods on Materials of Natural History Specimens: Part 1. Freeze-drying and freezing used in preservation of specimens and eradication of insect pests and microorganisms"

4. Mary-Lou Florian

"The Freezing Process - Effects on Insects and Artifact materials" (Leather Conservation News, Vol. 3. No.1, Fall 1986)

5. Mary-Lou Florian

Draft of "the Effects of Freezing and Freeze-Drying on materials of Artifacts and Prological Organism".

6. Keith O. Story

"Approaches to Pest Management in Museums" (Conservation Analytical Laboratory, Smithsonian Institution, provided as manual to "Pest Control Workshop" periodically given at C.A.L. by Dr. Gary Alpert)

Note: Readers will be particularly interested in the "Integrated Pest Management" program described in this publication.

7. Department of National Defence Canada

"The Manual of Pest Control" Fifth Edition (Canadian Government Publishing Centre, Supply and Services Canada, Ottawa, K1A 0S9, 1983),

Note: This publication contains excellent, large-scale, colour photographs of numerous insects.

8. John E. Dawson

"Insect Problems: General Guidelines" Canadian Conservation Institute (One-page handout).

9. Philip H. Ward

"Getting the Bugs Out" (Royal British Columbia Museum, Canada, 1976)

10. David Hillman and Valerie Thorp

"Museum Pest Management: The Collections Inspection Room" (Royal British Columbia Museum).

Julie Hughes

Textiles Conservation Laboratory
Canadian Museum of Civilization
Hull, Québec

FIRE AT THE SASKATCHEWAN MUSEUM OF NATURAL HISTORY

On the 16th of February 1990 at approximately 10:30 pm a fire occurred at the Saskatchewan Museum of Natural History. The intent of this article is to give a brief overview of the events leading up to the fire, problems associated with detection and control, the approach taken to clean up and the reasons for doing so.

In 1986 the Museum embarked on a major redevelopment project which when completed would result in completely new exhibits for the entire Museum. A decision was made to do this in 3 stages

over a 5 year period rather than completely close to the public. The first stage, an Earth Sciences Gallery, taking up 1/2 of the lower floor of our exhibit space was opened to the public in June of 1989. At this time work was well under way on developing the second 1/2 of the lower floor into a First Nations Gallery. Designs were also being developed for the upper floor which contained large natural habitat dioramas with animals and birds such as deer, moose, pelicans and whooping cranes.

One of the new exhibits being developed in the First Nations Gallery was a huge fibreglass replica of a rock wall with pictographs painted on it. This wall was erected between 2 and 3 feet away from the structural walls of the area. When the wall was touched or struck a rather hollow sound was produced, not at all like solid rock would sound. In an attempt to alleviate this a contractor was hired to spray expanding polyurethane foam insulation between the structural wall and the fibreglass wall. The was to form a number of pillars of insulation between both walls to make the fibreglass wall sound solid. Due to the toxic fumes produced by the reaction of the two resins arrangements were made to do the work in the evening after regular staff had left. On Friday evening February 16th the two contractors and a staff member assigned to grant them access to the area entered the building. Rather than build the pillars of insulation the contractors filled the entire void between the two walls with insulation and left. In some areas this resulted in a mass 3 feet thick and 10 feet high.

The employee assigned to the project locked up and went home. While

watching the late news an item caught his attention. The announcer was talking about a fire at the Museum of Natural History that was creating problems for Fire fighters because they could not find the source of the fire. The employee assuming the fire was in the area just worked on rushed to the Museum and led the Firemen to the fire. When they arrived on the scene the fire had begun to subside but it had consumed all of the insulation, most of the fibreglass wall, some other combustibles in the area and had burned through the gyproc on the fire side of the metal studs. Fortunately there were not more combustibles in the area so the fire did not manage to burn completely through the structural walls. Had it burned through the wall and ignited the combustible materials on the other side, the fire would have spread rapidly throughout the building.

The Fireman were hampered in fighting this fire in a number of ways. The primary one being a security system supposedly designed to assist rather than hinder. The system consists of a rather complex network of sensors throughout the building, smoke detectors in the air ducts and magnetic locks on all exterior and some interior doors. We had been assured that if an alarm sounded all magnets on the doors would automatically deactivate and there would be no problem evacuating the building. Fortunately the building was empty because the doors locked up tight and the Firemen finally had to break their way in through a Stainless Steel door. The fire detection sensors in the gallery under construction still had protective covers over them because the dust being created in the area could trigger false alarms. Therefore the alarm that the Fire Department received

came from a smoke detector in a return air duct at the opposite end of the building 90 metres from where the fire actually was. This, combined with the thick black smoke and soot, as well as the maze of corridors and hall ways in the exhibit areas, made it impossible for them to find the fire.

The Fire Department have completed their investigation and have ruled out all the usual causes such as electrical, mechanical, smoking on site and arson. They have not ruled out the possibility that the heat generated by the chemical reaction of the resins caused spontaneous combustion but they are not prepared to say that was definitely the cause. An insurance adjuster investigating the fire attempted to duplicate the foaming procedure in an outside environment. The foam did not ignite but it did reach a temperature of 300 degrees 6 inches below the surface.

Staff learned of the fire over the weekend either through news broadcasts or telephone calls from other staff members. When I heard I immediately telephoned the Director to inquire as to the condition of the exhibits and collections. I was advised that most were intact but heavily smoke damaged. He also indicated that the Fire Department was not allowing anyone into the area until they had completed their preliminary investigations and the air quality had been tested to be safe. The Director advised that Monday morning staff would meet at our Annex building to be briefed and begin planning our approach to clean up.

Monday morning an apprehensive staff gathered to hear the details and events of the weekend. At the meeting a committee

was struck to organize clean up efforts and I was assigned the position of Chairman. The Committee met at once to begin planning. A number of problems and issues were readily apparent others would surface as the days and weeks went by. We did not have a disaster or emergency plan to rely on and no one had any experience with this type of situation. We could not proceed on our own initiative due to a number of factors the main one being Government Red Tape and Proper Channels. Among other problems were the fact that we do not own the building or furnishings, they are leased from Saskatchewan Property Management Corporation (SPMC), and we do not have any insurance.

Initial questions were, "how bad is the damage? where do we begin clean up? how soon can we reopen? what do staff do?". A decision was made to relocate staff to our Annex building which housed Curatorial staff as well as the majority of the collections and to Government House Historic Property which is under the Museums mandate. Further decisions would be made after I had a chance to view the Museum and we had a meeting with SPMC which was already scheduled for the afternoon.

I then went to the Museum to do an initial inspection. Thick black fluffy soot covered everything that was in the open. In some areas this was over 1cm deep. Finer soot had permeated into every crack and opening covering everything in a layer of grey to black. Nothing in the entire building escaped this fine soot. Filing cabinets, cupboards, and display cases were no protection from the soot. All of the birds, animals, books, files etc. were covered with it. This fine soot was still

very thick in the air and any movement would generate more of it into the air. My inspection revealed that none of the collections had been damaged by fire or water. There were two reasons for this. First the fire was contained in the re-development area. Secondly, because the fire was almost extinguished when the Firemen found it they had not used much water. I was concerned that further damage might occur to the specimens from the soot that covered them so I collected several samples and arranged to have them analyzed very quickly by the Canadian Conservation Institute (CCI).

At our meeting in the afternoon with SPMC we realized that they had been busy over the weekend and were considerably more organized than we were. SPMC had insurance so their agent and a contractor the agent had already hired to supervise their part of the clean up were in attendance. The agent outlined his responsibility involving the clean up and their priorities. Basically the insurance covered the building and furniture so their main objective was to get the building cleaned up, repair the structural damage, clean the furniture and get the building ready for re-occupancy as quickly as possible. Since everything else in the building belonged to the Museum the agent was anxious to know what our approach to the clean up would be. I indicated that until the test results from the soot arrived we were not in a position to make those kinds of decisions. I also stressed the delicate nature of some of the specimens and the need for special precautions in some areas during their clean up because we could not remove some items from the gallery. The insurance agent was very co-operative from the beginning.

As the week progressed we received official clearance to enter the building and examine things more closely. I was fortunate to have two conservators working in the laboratory at the time. They began the task of testing various surfaces in the Galleries to determine the best method of removing the soot from the displays. By mid week the results from the soot samples arrived indicating that in a dry state it was stable and should cause no further damage. The report also indicated that organic solvents would extract highly coloured oils and tars from the soot which could spread into the specimens. Based on the report and the fact that the insurance company was anxious to get started a decision was made to proceed with the building and exhibits clean up first and leave the specimens for cleaning at a later date.

The building was sealed off into airtight zones and large power vacuum hoses operated constantly in these zones to remove airborne contaminants. The insurance agent arranged for a moving company to pack and move all the furniture out of the building. The Museum had no insurance dollars to rely on and only verbal approval to make expenditures with no assurances of where the money was to come from and we could not hire additional workers without jumping through all of the proper hoops with necessary paper work completed. Therefore the task of packing everything was done by existing staff and a few volunteers. Rubber gloves, disposable coveralls and dust masks were mandatory because nothing could be touched without turning black. At times during peak activity individuals experienced respiratory irritation and chest pains. When everything was packed and labelled a

moving firm delivered it to pre-arranged destinations. Due to the nature of the mounted bird and animal specimens in storage arrangements were made with the contractor to leave them in the building. Also the mounted specimens behind glass in the display cases were to remain in place during the cleaning operation.

A private cleaning company was contracted to do the building clean up. Arrangements were made to take them through the galleries and identify sensitive areas they were to be careful around as well as areas they were not to touch. The building clean up took place in three stages. First an initial sweeping and vacuuming, then a thorough washing and scrubbing of all areas and preliminary cleaning of carpets. While this was going on demolition and reconstruction of the structurally damaged area was also proceeding. Duct work, crawl spaces etc. received a protective spray coating of a product called "Kilz". This was followed by repainting, a final cleaning of carpets and floors and a complete building clean up before a final inspection and turning over of the building to the Museum staff for re-occupancy. The reconstruction and building clean up were completed May 29th, 1990.

Before and during initial clean up the Museum committee were planning our approach to the situation. The clean up and restoration was divided into three areas of priority. First priority was given to the Earth Sciences Gallery because it was less than one year old and appeared to have sustained the least damage. Second priority was assigned to the First Nations Gallery because it was in the development stage, would provide new exhibits, and for the most part would be

reconstructed by the insurance contractors. Third priority went to Upper Gallery because the area was scheduled for redevelopment in the near future and damage was much more extensive. I did not feel refurbishing badly damaged exhibits, only to have them removed in a few months, was an efficient use of resources or manpower.

Because some of the collections in storage could not be moved out of the Museum arrangements were made with the cleaning contractor to clean certain rooms first. When initial cleaning was completed in these areas quick-erect shelving, borrowed from SPMC, was installed and the specimens were transported to these rooms. The specimens remained in these rooms until their proper storage areas had been cleaned, painted, and received final clean up.

Part way through restoration the insurance agent started to express concern that the closed cases in the Upper Gallery containing natural vegetation and organic specimens was retaining the strong smoke odour and would re-contaminate the building. Until that time we had not made a decision as to the future of the exhibits because events following the fire caused us to question whether funds for redevelopment would be forthcoming. If the funding was not available we would have to attempt salvage of existing exhibits. A decision regarding funding was not imminent so arrangements were made to remove all natural vegetation from the displays. The mammals all received a light vacuuming to remove visible surface soot. The birds however, were not touched as they presented a special problem. All specimens were left in their display cases.

Conservation staff, with the aid of volunteers and occasional help from exhibits staff, undertook the task of cleaning the displays in the Earth Sciences Gallery and I initiated the necessary paper work to hire three temporary people to help us with exhibits and collections restoration. Most of the material was plastic or fibreglass of one type or another. Since there were very few actual artifacts in the gallery conventional, and some rather unconventional methods, were utilized. Initial cleaning involved removal of as much soot as possible utilizing dry methods such as vacuuming, air pressure and brushing. This was occasionally followed by dry cleaning with erasers or a sponge called a "chemsponge" that is designed to use dry. Because organic solvents had the potential to extract oils from the soot most wet cleaning involved water based solutions. Foliage that had large leaves was cycled through several solutions in large green garbage cans. A huge mass of foliage with tiny leaves was loaded into the back of a 1/2 ton truck and hauled to a self serve car wash where it was pressure sprayed with soapy water and rinsed. The paint along the top of a canvas mural was damaged by the intense heat carried with the smoke and could not be cleaned properly so the original artist was commissioned to repaint the top portion. Eventually, 12 weeks after the fire I received approval to hire 3 students for the summer. The additional manpower was greatly appreciated. We were able to restore the gallery to its previous condition and open it to the public on June 23rd, 2 1/2 months after the fire.

Attention then shifted to cleaning up the mountain of material that had been hauled to off site storage and the mounted

bird specimens that were in storage at the Museum at the time of the fire. The primary method of cleaning the stored non artifact materials was vacuuming and washing in water based solutions. The birds in storage had not been coated as thickly with the soot. Therefore an acceptable cleaning technique was developed that involved gently brushing the bird with a soft owl wing to remove loose soot. This was followed by placing a small piece of "Groom Stick" on an applicator stick and gently rolling along the bird with the feathers. Feet, beaks and eyes were cleaned with slightly damp ethanol swabs. By the end of August when the students had to return to school all material had been cleaned and returned to the Museum. The birds in storage were nearing completion and were completed by one staff member and a volunteer in September.

The birds in the Upper Gallery have a much thicker layer of soot on them which is proving difficult to remove. Several experiments were conducted on selected specimens in an attempt to develop a suitable technique. I did not feel any of the methods tried at the time were satisfactory so cleaning was put on hold. Eventually I decided to send two specimens to CCI. I wanted to reinforce my conviction that they need to focus on Natural History specimens in addition to their other projects and I was curious to see what techniques they might be able to come up with. CCI is continuing their work on this project. However, recent staff and budget cuts have prevented any further work on the project at the Museum. Therefore the specimens remain in the display cases uncleaned and the Gallery is closed to the public indefinitely.

As I think about the fire and events following I realize we were very fortunate that it was not worse. There are also a number of questions and issues that will never be resolved. The fire certainly created an emergency situation which could have quickly become a disaster. If the collections had been more seriously affected I believe they would have been lost because we did not have a disaster plan or the mechanism in place to mobilize the necessary resources quickly enough to have saved them. I also have to wonder how co-operative the Insurance agent would have been if we had told him he could not have access to the building and would have to put his contractors on hold until we were finished salvaging the collection. Or, if indeed, we could have told him to wait since we do not own the building.

A mechanism allowing us to insure our exhibits and collections certainly would have been beneficial. We could have proceeded with and completed clean up and restoration quickly if we would not have had to rely on Government for resources.

My advice to those of you who do not want to find yourselves in a similar situation is: make sure you have an up to date emergency plan in place, make sure you have a fire detection and suppression system in place that has been tested and proven to do what it is supposed to do, get your building and all contents insured, and finally do not assume an insulating contractor is completely knowledgeable about his products.

Don Pingert
Senior Conservator

Saskatchewan Museum of Natural History
Regina, Saskatchewan

NEW FROM TEXTILE LABORATORY, CANADIAN CONSERVATION INSTITUTE

The Textile Laboratory of the Canadian Conservation Institute has been kept very busy during the past months with treatments, seminars and visitors.

Earlier this year Pre-Columbian textiles from the University of Montreal were cleaned and mounted for use in a study collection. Costumes and accessories from the Dugald Costume Museum were recently returned to Manitoba upon completion of their treatment.

Work continues on the second of five 16th century tapestries from the Winnipeg Art Gallery. The removal of the old repairs, the rewarping and the reweaving of the tapestry are progressing steadily. Comprehensive written and visual records on the treatment of the tapestry are kept as the work proceeds. The embroidery and backing of a firescreen from an Ontario museum have been cleaned and are currently being remounted. Two beaded dresses from Yukon museums are under going conservation treatment. The lightweight silk dresses, with their beaded ornamentation, have presented many interesting conservation problems which require new solutions. A paper on their treatment is planned.

Along with the treatment of artifacts, the Textile Laboratory presented two seminars on the "Construction of Mannequins for

Historic Costumes" in Alberta and Prince Edward Island. A third seminar, on the same topic, is to be given soon in the Northwest Territories.

Over the past months the Textile Laboratory had a number of visits from European colleagues. The visits provided an excellent opportunity for the exchange of ideas. One visit of particular interest was that of Brigitte Dreyspring, Chief Conservator at the Deutsches Textile museum, Krefeld, Germany. Ms. Dreyspring presented a lecture on the museum's collection, the conservation problems encountered and the principles that guide her in finding solutions. Also of special interest was a visit from Sophie Younger, a Tapestry Conservator from Scotland. The different methods used in mounting large tapestries were discussed. The Textile Laboratory plans to gather various approaches to this problem and to share the information with others in the textile field.

September marked the return of Jan Vuori to the CCI after a leave of absence. Jan spent a year living in Vancouver where she worked at the University of British Columbia, Museum of Anthropology. The same month, Gaelen Gordon from the Sir Sandford Fleming Art Conservation Techniques Programme, began an eight month internship in the Textile Laboratory.

Textile Laboratory
Canadian Conservation Institute
Ottawa, Ontario

NEWS FROM THE McCORD MUSEUM OF CANADIAN HISTORY

The McCord Museum, located at 690 Sherbrooke Street, has been closed to the public since January 1989 for renovation and expansion.

Immediately following its closing three years ago, staff and a small army of volunteers began the enormous tasks of wrapping and packing McCord's seven collections: Costume and Textiles, Decorative Arts, Ethnology and Archaeology, Paintings, Prints and Drawings, Notman Photographic Archives, Archives and Library. More than 65,000 items and the 90 tons of Notman materials was moved, and set up in temporary quarters on St. Antoine Street.

During the three year renovation and expansion project, the staff has been very busy working towards the inaugural exhibitions, including research, development of storylines and writing catalogues to accompany the exhibits. In addition, much effort is going into the preparation of the nearly 1,500 objects chosen by the curators for display in the inaugural exhibitions. Some objects require treatment ranging from minor cleaning to major conservation and many need special mounts for display. Very skilled technicians joined the Exhibition Production team to help with the preparation of the objects. Weekly exhibition meetings help to keep everyone up-to-date and to identify and solve problems. The Museum is preparing for its re-opening with a series of major inaugural exhibitions in new and exciting exhibition spaces in a fully-renovated building. The objects not on view will be stored and protected in state-of-the-art

storage. Until this spring, conservation was carried out mostly by private conservators and with the assistance of the Canadian Conservation Institute and the Centre de Conservation du Québec. Last year monies became available from the Museum Assistance Programme to establish two conservator positions as well as that of a conservation technician to set up labs in the new building. In April I began at the McCord as the Costume and Textiles Conservator and in May I was joined by Bruno Pouliot, Objects Conservator, formerly at the Prince of Wales Heritage Center, Yellow Knife, N.W.T..

The last six months have been very busy between ordering equipment for the new labs and readying artefacts first for catalogue photography and then the grand opening exhibitions. This pace will have to continue at least until our re-opening in May 1992.

The McCord Museum is also very fortunate to have a large group of volunteers who contribute their time to make mounts for both exhibition and storage and assist in conservation projects.

So far so good! Everything seems to be working well inspite of the inevitable minor snags which only remind us of the enormous challenge we are all involved in. We are now preparing for our return to 690 Sherbrooke Street. I am looking forward to a great building and a brand new Costume and Textile Conservation Lab, and the re-opening of the Museum in May of 1992.

Eva Burnham
McCord Museum of Canadian History
Montréal, Québec

NEWS FROM GAIL NIINIMAA, PRIVATE CONSERVATOR

S. Gail Niinimaa has recently moved into her newly built 300 sq ft Conservation lab in her house complete with a small wash table. The greatly expanded space has allowed her to begin in earnest working privately in Textile Conservation for both the private sector and museum community. The majority of the work to date has been mounting small to medium sized textiles for framing. Wet cleaning projects include Christening and Wedding gowns, samplers embroideries, small rugs and two Ukrainian dance shirts. The flexibility of working part time has allowed her to remain at home with her two small daughters. Recently she started to advertise and produced a small brochure and hopes to generate enough work this autumn with fall to devote 1 day per week to Textile Conservation.

25 Cathedral Rd., N.W.,
Calgary, Alberta
T2M 4K4

NEW PUBLICATIONS

NESAT III: Textiles in Northern Archaeology

The study of archaeological textiles is a relatively new branch of archaeology, but one that is growing rapidly throughout the world. NESAT - the Northern European Symposium for Archaeological Textiles - was founded in 1981, as a forum for textile researchers in northern and central Europe to discuss their work and publish it. The first Symposium (1981) was held at the Textilmuseum in Neumunster (N.

Germany); in 1987 NESAT met in York (England) and the present volume contains 25 of the papers delivered at, or offered to, the meeting. Most are brief reviews of important textile groups or objects; a few are reports on major projects. Chronologically the papers span five millennia, from Mesolithic netting to the costume of 17th-century Danish royal children. They are supplemented by some purely technical studies (on freeze-drying) and on fibre wear seen with SEM). Most contributions, however, are non-technical and should appeal to historians, archaeologists and conservators - and to all with an interest in the textile past.

The text is richly illustrated. The colour cover shows a striking reconstruction of the silk and gold Anglo-Saxon embroideries from Maaseik (Belgium).

Details: 244 x 184mm, 231 pages, 234 figures (including line drawings and black-and-white illustrations) printed on coated cartridge paper with laminated full-colour cover. Edited by P. Walton & J.P. Wild. Published by NESAT and produced by Archetype Publications, London, 1990. ISBN 1 873132 05 0

Price: £16.50, plus £1.90 for postage & packing. Send order to Dr. J.P. Wild, Manchester Ancient Textile Unit, Department of Archaeology, The University, Manchester, M13 9PL, UK. Cheques should be drawn in £ sterling and made payable to "North European Symposium for Archaeological Textiles" (Institutions which cannot pay in advance can be invoiced.)

BOOK AND EXHIBITION REVIEW:

"BEVARANDETS HEMLIGHET - KONSTEN ATT VARDA, FORVARA OCH KONSERVRA"

"THE SECRET OF PRESERVATION REVEALED - THE ART OF CARE, STORAGE AND CONSERVATION"

LIVRUSTKAMMAREN, SKOKLOSTERS SLOTT AND HALLWYLSKA MUSEET

I had an opportunity to see the exhibition "The Secret of Preservation Revealed" at Livrustkammaren (The Royal Armoury) in Stockholm, Sweden in June 1991. This special exhibition on from June 1, 1991 - February 15, 1992 has been made to raise the public awareness of Conservation.

An elaborate catalogue, in Swedish, has been produced as a companion to the exhibition. The catalogue has many B/W and colour photos which all have English captions. The catalogue includes detailed information on pieces from the exhibition and has been written in a condition/treatment report format.

The exhibition deals with all aspects of Conservation but the specialties of Conservation have been divided among the three institutions. Skokloster Slott deals with building restoration and conservation of artifacts, Hallwyska shows Paper Conservation and cleaning paintings with enzymes and Livrustkammaren deals with Textile and Metal Conservation. I will review the exhibition at Livrustkammaren, which was very interesting.

At Livrustkammaren, they chose to compare the treatment of textiles to that of a person requiring medical attention. There are 5 exhibition rooms which deal with the various aspects of Conservation. The 1st room shows worn objects awaiting treatment and the type of problems that may be encountered in Textile conservation.

Room two has on display, many for the first time, 8 Black garments worn by King Karl X Gustav of Sweden who reigned between 1654 - 1660. These 8 garments have very different details and are a unique and valuable source of information for social historians, art historians, textile historians and dress historians alike. Due to the extremely fragile nature of the garments the Textile Conservators planned an elaborate exhibition system. On first glance as you pass through the room it appears to be an empty room with Black Cabinets along one wall. On further examination it is revealed that the cabinets contain these special artifacts and the light is controlled so that each individual cabinet is only illuminated when the cupboard door is opened. The garments lie on a slight incline on a fabric covered board and are stuffed out with tissue paper to maintain the proper shape. There is a 6 page English summary about the Garments in the catalogue.

Room three is entitled "Treatment and Conservation" and a replica of a Textile Conservation lab has been set up. As there are no artifacts in this room the light levels are quite high. The room is full of examples of the type of work that is done in a Textile Conservation lab; copies of actual treatment reports, examples of supplies used, equipment used for analysis, description of the dyeing process for new

fabrics, light level metres and the importance of readings, analysis of dirt, pH testing, washing procedures and mounting procedures. Room three also deals with handling and conservation of metal.

Room four is entitled "Textile Conservation - preserving fragile objects" and shows many objects after they have undergone treatment. They have used a clever approach, by having a very similar artifact to one shown in Room one, but here, it is shown after it has undergone Conservation.

Room 5 shows the ideal storage for textiles and has examples of proper methods of storing both textiles and metals. The exhibition closes with a question to the visitors; "Yesterday, today and tomorrow - or what will happen in 100 years?". The message that is delivered is that conservation is a necessary step in ensuring the longevity of the collections.

This exhibition was very interesting to see as the focal point was to show what conservation is and how it is done. There was a great deal of in depth documentation shown about the treatments and the individual artifacts. I was quite impressed that they would devote their entire temporary gallery space to demonstrate to the public how important and necessary conservation is. Unfortunately there is very little English in the catalogue as I feel that for the Conservation community their catalogue is a good resource. The Catalogue sells for about 100 SEK, (\$18.00) and is available from Livrustkammaren, Kungliga Slottet, Stockholm, Sweden. An interesting marketing angle that they presented was that with the catalogue in hand you may

gain free entry into any of the three exhibitions

Gail Niinimaa
Private Conservator
Calgary, Alberta

RESEARCH

ATELIER REGIONAL DE CONSERVATION (A.R.C.) Nucleart, a regional conservation centre is presently involved in a research program to establish the best possible method of treating textile objects that have been attacked by mould or insects by means of gamma irradiation. A.R.C. Nucleart is equipped with a source of Cobalt 60. The conservation and research departments of the Museums of France and the Monuments Historiques support the project which is also assisted by the Centre for Research of the Conservation of "Documents Graphiques" and The Textile Institute of France. The project is financed by the Regional Council of the Rhône-Alpes.

The experience of practising conservators, conservation students along with that of curators of textile and costume collections is invaluable and will serve to assess the awareness of such a treatment and provide a means to evaluate the level of information required.

The criteria required by conservators and curators will assist in guiding the research in the necessary direction, and the research will benefit from your experience and opinions.

If you would like to receive the questionnaire or would like further

information please write to:

A.R.C. Nucleart
Centre d'Études Nucleaires de Grenoble
85X avenues des Martyrs
38041 Grenoble Cedex
France

FELLOWSHIP

VERONIKA GERVERS Research Fellowship in Textile and Costume History, Royal Ontario Museum

The Veronika Gervers Research Fellowship, supported by a memorial fund established in 1979, exists to promote research incorporating the textile collections of the Royal Ontario Museum (ROM), Toronto, leading to publication. *Applications are encouraged from all areas of textile and costume history.* An annual fellowship of up to \$9,000.00 (Can.) is available to Ph.D candidates, junior and senior scholars whose research can make direct use of, or support, any part of the ROM collections. The award will cover travel and living expenses while in Toronto or travel to do research relating to the collections.

Eligibility

Eligibility for the Fellowship is determined by a committee of scholars from the museum and university communities who, with the assistance of outside evaluators when necessary, will decide on the successful application. They reserve the right to withhold the fellowship if none of the projects are deemed suitable. Any adult, regardless of sex, race religion or

national origin may apply. Successful foreign applicants are responsible for obtaining any necessary visas, permits, etc.

Dates and Deadlines

Applications must be received by *November 15* and notification of results will be made on or before *January 31* each year.

For more information please write to:

Royal Ontario Museum
Textile Department
100 Queens Park
Toronto, Ontario
Canada
M5S 2C6
Tel: (416) 586-5790

For further information, please call:
Katherine Dirks
(202) 357-1889

A one page, typed proposal should be mailed to:

Fonda Thomsen
Textile Preservation Associates
P.O. Box 606
Sharpsburg, MD 21782

Proposals must be received by February 14, 1992.

Planning Committee:

Kathleen Betts
Meg Loew Craft
Katherine Dirks
Margaret Fikioris
Jane Merritt
Fonda Thomsen

CONFERENCE

HARPERS FERRY REGIONAL TEXTILE GROUP - CALL FOR P A P E R S & M E E T I N G ANNOUNCEMENT

For Our 11th Conference on SILK at the Smithsonian Institution, Washington, DC

Our meeting will comprehensively address topics relating to the conservation of silk.

Specific topics we hope to include are:

- Physical and chemical properties of silk
- Processing and manufacture of silk (historic)
- Structure
- Treatment of degraded, archaeological, painted, and furnishing silks, costume, accessories, and flags
- Silk used in treatments (crepe-line, linings, reweaving, sewing)

EXHIBITIONS

CANADA

Ukrainian Tradition

To mark the one hundredth anniversary of the arrival of the first Ukrainians to Canada, an exhibition including shirts, towels, headdresses and embroideries is mounted in CMC's Arts and Traditions Hall.

Until February 23, 1993

Heritage Wall

This exhibit acknowledges the diverse cultural origins of Canadians by presenting a rotating selection of artifacts. Of particular interest is a flat-woven rug (Kilim) currently included in this show. Canadian Museum of Civilization, Hull Québec from July 29, 1991

Oriental Rugs

Royal Ontario Museum
Toronto, Ontario
until January 5, 1992

Bienvenue: Textiles of Quebec

Museum for Textiles
Toronto, Ontario
until February 14, 1992

Traditional Hungarian Embroidery

Museum for Textiles
Toronto, Ontario
until January 1992

Parading Through the 1900's, uniforms and accessories from 1905-1970

Joseph Brant Museum
Burlington, Ontario
until November 24, 1992

Art Fashion: Great Fashion Illustrators of the Twentieth Century

Tudor Hall at Ogilvy's
Montreal, Quebec
until December 14, 1991

UNITED STATES

Samplers and Samplermakers

1700 to 1850
Los Angeles County Museum of Art
Los Angeles, California
until February 2, 1992

Kilim and Pile Rugs-

Kuba Embroideries and Pygmy Bark Cloths
M.H. de Young Memorial Museum
San Francisco, California
until November 1, 1991

African Dress and Personal Adornment

Indianapolis Museum of Art
Indianapolis, Indiana
until February 16, 1992

Halston: Absolute Modernism

Fashion Institute of Technology
New York, N.Y.
until January 11, 1992

Early Islamic Textiles

Cleveland Museum of Art
Cleveland, Ohio
until Fall 1992

Chancay Textiles from Peru

Haffenreffer Museum of Anthropology
Providence, Rhode Island
until December 22, 1991

Fabric of the Inca Empire

Mamluk and Ottoman Carpets
Textile Museum
Washington, D.C.
until January 5, 1992

SUBSCRIPTIONS

The **TEXTILE CONSERVATION NEWSLETTER** is published twice a year in the spring and fall. The two year subscription costs:

North America 29.00 Cdn.
Outside North America 39.00 Cdn.

Back issues of **TEXTILE CONSERVATION NEWSLETTER** and Supplementaries:

North America - 4.00 Cdn.
Outside North America - 5.50 Cdn.
postage and handling included.

Method of Payment

Our bank has recently returned some money orders (some drawn on Canadian banks) from outside Canada and U.S.A. that did not have the sufficient encoding for the bank in Canada to process them. These items cost TCN from \$3.75 to \$10.00+ to be hand processed which quickly reduces the funds available for producing the Newsletter. When ordering back issues or subscriptions, please request an "International Money Order" drawn on a Canadian clearing bank encoded with the following three part coding line:

(5 digit no.)-(3 digit no.)-(acct. no.)
(branch code) (bank code)

Thank you for your cooperation.

SUBMISSIONS

We welcome submissions on:
Textile Conservation, History Technology, Analysis and information on upcoming courses, conferences and exhibitions. Submissions address changes and correspondence should be addressed to:

TEXTILE CONSERVATION NEWSLETTER P.O. Box 4811, Station E.
Ottawa, Ontario Canada K1S 5J1

Please send all submissions in typed form or if possible produced on IBM compatible Wordperfect 4.2, 5.0 or 5.1 on 5 1/4" or 3 1/2" disk. Submissions sent by electronic mail (FAX) are welcome but if there are any illustrations that accompany the article, they will not reproduce well. We would appreciate it if the illustrations could be sent by mail or courier if time is running out. For the best production of illustrations and clear black and white photographs, copy-ready artwork is required. Your disks will be returned but we cannot return the artwork. Articles can be as short as 1 page and as long as 6 or 7. Anything longer than that will be considered for publication as a Supplementary.

Editors: Eva Burnham
Ruth K. Mills

Subscriptions: Eva Burnham

Treasurer: Ruth K. Mills

Disclaimer

Articles in the **TEXTILE CONSERVATION NEWSLETTER** are not intended as complete treatments of the subjects but rather notes published for the purpose of general interest. Affiliation with the **TEXTILE CONSERVATION NEWSLETTER** does not imply professional endorsement.

Deadlines for 1991/92 are: 1 Sept. and 1 Feb

ISSN 11-80-3649

TEXTILE CONSERVATION NEWSLETTER SUBSCRIPTION**NAME:****MAILING ADDRESS:****SUBSCRIPTION TERM: 91/92****INSTITUTIONAL SUBSCRIPTION:****PERSONAL SUBSCRIPTION:****BACK ISSUES (Please Specify):**

Please make cheque, money order* or bank draft in Canadian Funds payable to:
"Textile Conservation Newsletter". Mail to TCN, P.O. Box 4811, Station E, Ottawa,
Ontario, Canada K1S 5J1

* Please request an " International Money Order" drawn on a Canadian clearing
bank encoded with the following three part coding line:

(5 digit number) - (3 digit number) - (account number)
(branch code) (bank code)

