



---

Article: Francesca Woodman's *Untitled* Diazotype

Author(s): Dana C. Hemmenway

*Topics in Photographic Preservation, Volume 15.*

Pages: 426-437

Compiler: Jessica Keister

© 2013, The American Institute for Conservation of Historic & Artistic Works. 1156 15<sup>th</sup> St. NW, Suite 320, Washington, DC 20005. (202) 452-9545, [www.conservation-us.org](http://www.conservation-us.org). Under a licensing agreement, individual authors retain copyright to their work and extend publication rights to the American Institute for Conservation.

*Topics in Photographic Preservation* is published biannually by the Photographic Materials Group (PMG) of the American Institute for Conservation of Historic & Artistic Works (AIC). A membership benefit of the Photographic Materials Group, *Topics in Photographic Preservation* is primarily comprised of papers presented at PMG meetings and is intended to inform and educate conservation-related disciplines.

Papers presented in *Topics in Photographic Preservation, Vol. 15*, have not undergone a formal process of peer review. Responsibility for the methods and materials described herein rests solely with the authors, whose articles should not be considered official statements of the PMG or the AIC. The PMG is an approved division of the AIC but does not necessarily represent the AIC policy or opinions.

---

## Francesca Woodman's *Untitled* Diazotype

Dana C. Hemmenway

*Presented at the PMG session of the 2002 AIC Annual Meeting in Miami, Florida.*

### INTRODUCTION

In 1996 The Metropolitan Museum of Art (MMA) acquired a photograph by Francesca Woodman as a gift from a friend of the artist. It belongs to larger body of work that culminated in *Blueprint for a Temple* a work Woodman showed at the Alternative Museum in the spring of 1980. The image depicts an over life-size standing female nude, the artist herself, in tones of brown.

As the first diazotype to enter the collection of the Department of Photographs, curatorial and conservation staff sought confirmation of the photographic medium along with information about the process and its vulnerabilities. The author undertook this research as part of a 1996 student project for the Winterthur Museum/University of Delaware Program in Art Conservation. The objective was to provide background information on the history and chemistry of the process, perform scientific analysis to confirm process identification, seek a technical explanation of how diazotypes were made, and propose how Francesca Woodman was able to use the medium for her artistic purposes. Empirical tests were conducted on small samples of a similar diazotype material to provide some preliminary information as to what, if any, treatment techniques could be undertaken.

### THE HISTORY OF DIAZOTYPES/ USE IN INDUSTRY

The development, production and expansion of the synthetic dye industry is inextricably linked with the achievements of chemists working in



Fig.1. Francesca Woodman (American, Denver, Colorado 1958-1981 New York), *Untitled*, ca. 1980. Diazotype. The Metropolitan Museum of Art. Purchase: The Herbert and Nannette Rothschild Fund Gift, in memory of Judith Rothschild, 1996, (1996.322), 187 x 93.4 cm (73<sup>5</sup>/<sub>8</sub> x 36<sup>3</sup>/<sub>4</sub>”). Courtesy of Betty and George Woodman.

the 19<sup>th</sup> century. They were applied to a multitude of fields where inexpensive color was desired. Diazo or azo dyes are a class of synthetic dyes that can produce many different colors by manipulating the fundamental coupling components. Kalle and Co. in 1920 introduced a dry process paper that contained the necessary two coupling components in the same paper (Brown 1944,146). It was this product, a dye line on white background, processed without wet chemistry, which proved most successful for the reprographic industry.

There are several good reasons for the diazotype's overwhelming commercial success and great appeal for the architect or engineer in the 20<sup>th</sup> century. They were simple to produce, inexpensive, offering speed, efficiency, and the ability to reproduce any number of copies from a single run. Dry processing ensured no dimensional change. A special class of diazotypes, called Sepia Line, was manufactured to function as a draft or intermediate copy. Corrections could be made directly onto the brown-toned sepia copy and then it was used to generate final copies available in colors such as blue, purple and black. By the turn of the 21<sup>st</sup> century the diazotype industry was largely supplanted by computer-based technology.

### **CHEMISTRY OF A DIAZOTYPE**

Producing a diazotype relies on two basic chemical reactions. First, a diazonium compound (an aromatic ring with two nitrogen atoms) will yield a dye molecule when combined with an appropriate coupler under alkaline conditions. The combined compound contains an extended conjugated bond. Second, a diazonium compound can be chemically altered or deactivated through photodecomposition by ultraviolet (UV) radiation so that in alkaline conditions it can no longer combine with the coupler to produce a dye. The diazonium compound then is either deactivated by exposure to UV (losing its ability to conjugate), or it will create a colored dye.

According to a representative of the Azon Corporation in 2002, the chemistry and formulations employed to manufacture diazotypes had not changed much since the late 1940s when the company was founded. There were several features critical to making the dry diazo system work for commercial purposes: adequate shelf life, non-yellowing paper, dyes with high tinctorial strength in various colors, and the addition of chemicals used to stabilize the coupling compounds to prevent premature coupling or discoloration (Lay, 2002).

The paper support needed to be hard sized, dense and resistant to penetration of upper coatings, and free of impurities that could react with dye forming compounds. To serve its function as an intermediate, the paper furnish of a sepia diazotype needed to be UV transparent in non-image areas. Fibers were made of highly beaten cotton and/or purified wood pulp (low lignin content) and were further transparentized by the addition of an oil or resin. The sepia paper supports also were manufactured to be thinner than the opaque varieties (Moser 1950, 232 & Lay 2002).

The paper base was pre-coated with a silica dispersion to enhance image quality by dramatically increasing the surface area for dye molecules to deposit onto, creating a dense velvety appearance. The pre-coat hindered diffusion of the acidic, image-coating layer into the support (feathering). This layer also provided tooth to facilitate the addition corrections directly to the intermediate. (Lay, 2002).

The final coating layer consisted of a solution of a diazonium salt, a coupling agent and numerous additives. Final image color was derived from carefully selected combinations of the diazonium molecule and coupler compound. The nature, number and position of the substituents influenced the color of the azo dyes blue, black, purple and sepia (Kosar 1965, 215). Sepia diazotypes contained a combination of resorcinol and its derivatives as couplers. A combination of yellow and red dyes produced a brown or sepia tonality. The resulting dyes needed to be dark enough for use in office conditions and opaque to UV radiation in order to produce the next generation of copies (Lay 2002).

Numerous compounds were added to improve diazotype keeping abilities and appearance. Zinc chloride was included to stabilize the diazonium compound, increased coupling speed, and chelate with the dye producing a stronger image (Kosar 1965, 294). Chelation of the dye further functioned to reduce the mobility of the relatively small sepia dye molecules (Lay 2002). Citric acid was included to maintain the acidic environment in the paper necessary to retard premature coupling and increase the light sensitivity of the diazonium compound (Brown 1944, 186). Thiourea was added as an antioxidant to counter yellowing of the background areas caused by oxidation of phenols. Optical brighteners were added to paper stock to promote brightness and visually counteract yellowing.

### **CAUSES OF DETERIORATION**

Diazotypes display significant deterioration problems in part from inherent vice and their sensitivity to environmental factors. Since the print is processed dry, compounds used to create and stabilize the dyes were never removed within the processing sequence. This is manifest in three ways: background darkening, dye discoloration, and increased base layer brittleness.

Deterioration can begin prior to exposure and development. It is caused by the decomposition of the diazonium compound itself as well as the premature coupling of diazo compounds with couplers. Unconsumed coupling components (typically phenols) and photodecomposition products (deactivated diazonium) remain on the paper surface. Oxidation of these compounds produces unwanted background discoloration turning non-image areas yellow and eventually brown. This is promoted by excess of alkali retained from the development (Kosar 1965, 293).

Azo dyes are susceptible to loss of color through oxidation and photolysis. Dry diazotypes often remain acidic after production and this can affect the stability of the paper support. Finally, the transparentizing medium added to the paper base of the sepia diazotype can age and may affect the stability of the paper support. (Kissel 1999, 39 & 66).

### **WOODMAN'S *UNTITLED DIAZOTYPE***

The figure in the MMA diazotype depicts the artist herself as a standing nude that begins at the neck and concludes just below the knees (Figure 1). She is holding a bulb release to trigger the shutter and capture the image from a distance. The image tone is dark reddish brown. Image density is the darkest at the top and bottom margins that lie outside the image proper. Rounded corners, defining image from non-image areas, are found on the lower and upper left margins. They mimic, perhaps, the format of a slide used to enlarge the image. Texturing was expressed

and enhanced through smudge-marks and huge fingerprints superimposed around the body and across the background. The print measures approximately 73-5/8 inches high by 36-3/4 inches wide (187 x 93.4 cm) and is roughly cut at the top and bottom edges. The sides are even, indicating that the photograph dimensions are bound by width of the paper as manufactured. Paper fibers can be seen on the recto surface with magnification. The paper support is thin and partially translucent.

### CONDITION

On examination in 1996, the image layer appeared to be in fairly good condition. However, horizontal bands of lighter and darker areas across the print were visible from the recto and verso. The photograph was likely rolled for storage and the banding revealed where a poor environment may have affected the print. The result was loss of image density and yellowing of the background color.

The support was somewhat brittle. White V-like creases in the paper support were evident along the left and bottom right sections of the print. These were probably the result of physical distortion from handling. The verso surface showed yellowing and darkening.

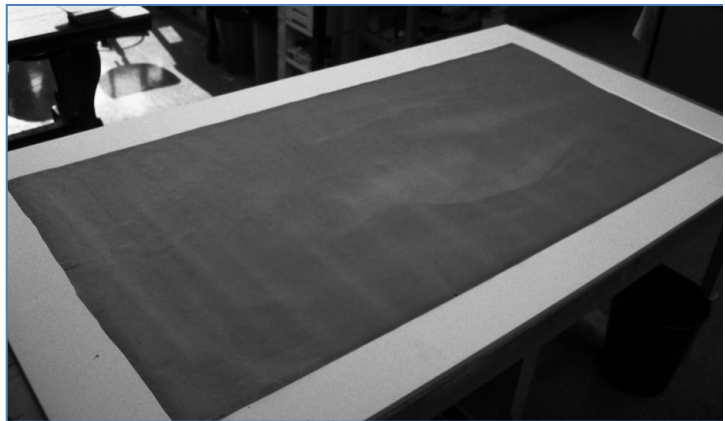

Fig. 2. Verso of F. Woodman's *Untitled* diazotype. Courtesy of Betty and George Woodman.

### CONFIRMATION OF THE PHOTOGRAPHIC PROCESS

The Woodman print displays key hallmarks of a sepia diazotype. These characteristics have been clearly laid out by Kissel and Vigneau in their publication on 20<sup>th</sup> century architectural reproductions (Kissel, 1999). They include: the brown image tonality, translucency of the support, yellowing, and white handling dents.

A small sample from the Woodman photograph, containing high image density, was provided by the MMA for destructive and non-destructive analysis. In 1996 the author worked with Kate Duffy, then Assistant Scientist at the Winterthur Museum Analytical Laboratory, to seek analytical confirmation of the photographic process. The instruments used were: an X-Ray Fluorescence Spectrophotometer (XRF), Scanning Electron Microscope (with energy dispersive detector) (SEM-EDS), and a Fourier Transform Infrared Spectrometer (FTIR) (Duffy 1996).

XRF was used to detect the presence of typical photographic metal image formers such as: silver, iron, platinum, palladium, or chromium, however only Zinc was detected in the print. SEM was then used to confirm XRF data with the possible additional detection of elements lighter than potassium. The largest peaks were attributed to silicon and zinc, with sulfur and chlorine in lesser amounts. For comparison, an additional sample, obtained by an architect who retained

samples from the early 1980's, was run under the same conditions. Again, silicon, sulfur, chlorine and zinc were detected. FTIR analysis was performed to detect organic materials present. Cellulose peaks (the paper support) were found as were peaks that strongly suggested the presence of oil. Additional peaks may indicate an additional material such as silicates (Duffy 1996).

Finally, Debora Mayer, a fiber identification expert, performed analysis on the last remaining portion of the original sample. She concluded that the sample fibers were highly beaten cotton. In addition, fine particulate material was detected on and around the fibers. This may indicate a protein, oil, resin, or synthetic component. The combination of materials and processes used to manufacture the paper yielded a paper that was tough, difficult to tear, did not take up water easily, was semi-translucent, and heavily sized (Mayer 2002).

## **RESULTS AND CONCLUSIONS OF ANALYSIS**

Diazo prints of any color make use of organic dyes to provide hue, and so the absence of a metal image-former was not surprising. The presence of zinc and chlorine was also not surprising as Zinc Chloride ( $ZnCl_2$ ) was often added to the sensitizing solution as a stabilizer. Some diazotype formulations employed a colloidal dispersion of silica. Sulfur may be present as thiourea was typically added as an antioxidant to offset the tendency of diazotypes to yellow. The presence of transparentizing oil was consistent with all technical descriptions of sepia line diazotypes. Shelly Lay at Azon Corporation later confirmed that a synthetic resin was employed for papers they manufactured in the 1980's (Lay 2002). Heavily beaten fibers further enhanced the transparency of the paper support. Thus, the presence of each of the elements detected through analysis can be explained - as can the absence of others, such as iron or silver.

## **HOW TO MAKE A DIAZOTYPE**

In order to understand the techniques Woodman used to make her prints, it is helpful to know how a typical diazotype was made. The schematic drawing (Figures 3 & 4) illustrates the two necessary components of a desktop processing unit, the exposing unit and developing chamber.

Depending on the model, an operator inserted the original face up on top of a bright yellow sheet of unexposed diazo paper or the original was met with a continuous roll of the diazo paper once inside the machine. Both were transported by conveyor belts through an exposure chamber, typically equipped with a high-pressure mercury-vapor lamp as the source of UV radiation. The original was then fed out of the unit and the copy was automatically taken into and through the developing chamber containing heated aqueous ammonia vapor. The whole process took no more than a minute (Kosar 1965, 253).

Unlike blue prints or cyanotypes, diazotypes are a positive rendering of an original. During exposure, UV radiation that penetrates clear or minimum density of an original destroys the diazonium compound directly. Dark or opaque areas of the original will block UV waves and protect the diazonium compound below. The preserved diazonium compound can then go onto to form a colored dye when exposed to ammonia vapor. Thus, it is a direct positive copy of the original.

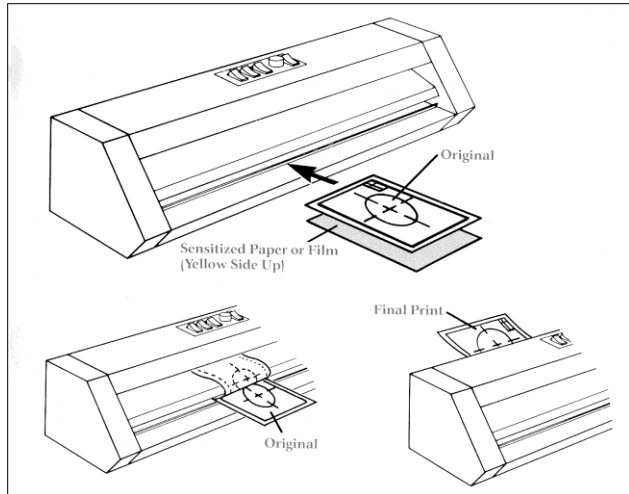

Schematic rendering of a diazotype processing unit. (From Rotolite 1987).  
 Fig. 3. Entry point for original.

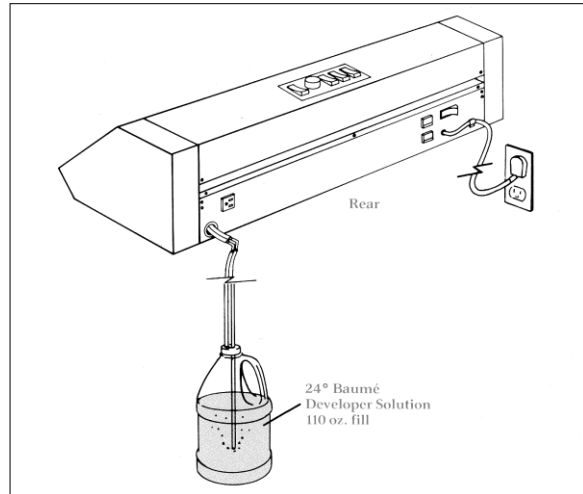

Fig. 4. Source of ammonia.

### ARTIST'S WORKING METHOD

Woodman was well versed with gelatin silver technology from image capture to printing, it was the predominate photographic process for artists of her time. Diazotypy offered a very different look, scale, and cost. However, it also posed technical hurdles that needed solving.

According to Betty Woodman, the artist's mother, Francesca had been experimenting with diazotypes after graduating from art school. She used a print shop located somewhere near Union Square in New York City to process her pictures. Further, she had worked with one particular employee who assisted her with large-scale diazotype papers in blue and brown (Kennedy, 1997). In fact the family kept a diazotype box owned by artist. The label information was as follows:

Sepia Line/ Diazotype Paper for Ammonia Development  
 Azon, Johnson City, NY  
 Cat 4516 Size 36 x 100  
 Lot No. 0535444.

Woodman created diazotypes using two different methods. In a 2002 interview, George Woodman showed the author several examples of "templates" his daughter assembled that were later used to produce diazotypes (Woodman 2002). Figure 5 shows an example containing gelatin silver positive transparencies attached with pressure sensitive tape to a thin sheet of translucent paper. Some of these assemblies combined photographs with sketches and writing. The template would have been superimposed onto a sheet of diazo paper, then exposed and developed in a commercial processing machine. The resulting diazotype was a contact print of the original. Figure 6 illustrates the finished sepia diazotype.

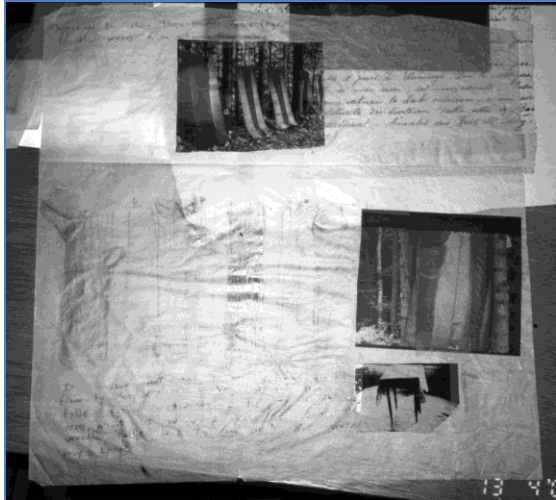

Fig. 5. F. Woodman, assembled template.

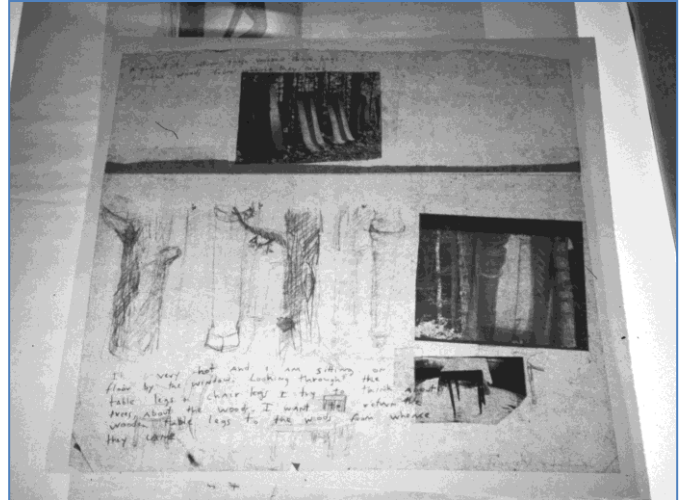

Fig. 6. F. Woodman, sepia diazotype.

Courtesy of Betty and George Woodman.

Woodman used projection to achieve the large-scale human figures by exploiting the size potential of diazo rolls of paper (36 inches wide and many yards long,). According to her father she experimented at first with 35mm positive slides and a projector to enlarge the image. A sheet of diazotype paper was taped or tacked to a wall in a darkened room either in her studio on Duane Street or in parents' apartment on 17<sup>th</sup> Street. The distance between the projector and the wall determined the scale of the image.

As has been mentioned previously, diazonium compounds are most sensitive to ultraviolet radiation and professional printers used a high-pressure mercury-vapor lamp for exposure. Fortunately, diazo papers will also respond, if slowly, to tungsten bulbs. Betty Woodman estimated up to 12 hours of exposure in some cases, along with burnt out bulbs and distorted slides. The author experimented with blue and sepia diazotype paper in 2002 and was able to produce an image using a projected black and white 35mm slide for several hours and development with ammonia vapor.

Francesca's ally in the blueprint shop near Union Square gave her a Beseler lantern projector that could accommodate Francesca's larger format transparencies. It also contained a more powerful lamp, which may have improved magnification ratios and decreased exposure times. Her father further suggested that she would trim large format film to fit into this projector format. The rounded corners and a darkened non-image area could have been introduced through the lanternslide holder itself or through the addition a typical lanternslide mask. A series of images published in a 2011 exhibition catalogue bear a striking resemblance to the MMA's *Untitled* diazotype, and were likely taken in the same photographic session (Keller 2011, 130 & 131). These related images bear the hallmarks and proportion of a sheet of 4 x 5 inch film. What might have been sacrificed in contrast or detail through enlargement has been remedied by the addition of the smudge marks added directly to the film by hand.



Development, on the other hand had, to be carried out in the blueprint shop by a knowledgeable technician. Processing the already exposed enlargements required bypassing the exposure unit by feeding the prints directly into the ammonia chamber.

Since diazotypy relied on a positive to create a positive, Woodman needed to convert her negatives into positives for source material (see Figure 5). In the early 1980's, there were several ways to produce positive transparencies from camera negatives. A roll of Panatomic-X 35mm film could be processed using reversal chemistry. Or, for larger film sizes, a fine grain duplicating film (such as Kodak's 7302 Fine Grain Positive film) made for creating movie prints, could be used to produce silver gelatin positive transparencies through contact printing or enlargement (Sampson, 2013). Woodman used a variety of film sizes: 35mm, medium and large formats; any of these sizes could be converted to a positive using typical darkroom equipment.

### **TREATMENT OPTIONS**

To explore options for the treatment of diazotypes, simple empirical tests were carried out on study collection samples taken from a sepia diazotype from the early 1980's. The print bore similar characteristics with Woodman: image color, yellow discoloration at the edges, translucency of the paper support, and white crease marks. (Please see appendix for procedural details.)

The results point out some noteworthy changes. While this test did not try to replicate exhibition conditions, the sample displayed significant dye fading and background discoloration. Image color changes were noted in immersion testing. Loss of color was observed with both ethanol and acetone baths and shift in color was noted particularly in the alkaline baths. This latter change could indicate a loss of overall yellowing as a result of aging, or an actual shift in the color of the dye itself or both. Organic solvents appeared to extract the solvent-soluble resin from the paper base and increased opacity in the print. Water-soluble optical brighteners were lost in aqueous baths.

### **CONCLUSIONS**

There is an interesting contradiction between the more ephemeral aspects of Woodman's chosen photographic medium for this project and the monumentality of her subject matter, a caryatid, intended for a temple. It provides some insight into the ingenuity and creative power of an artist who repurposed a medium designed to be quite literal. Industry's intended function for the sepia diazotype, or second original, was incidental for Woodman, she merely appropriated the medium's potential and effect for her powerful expressive purposes. As a consequence however, Woodman left behind a body of work that was fragile, and environmentally sensitive. Conservators are now faced with difficult task of preserving artwork that was developed for the short term. Additional research is needed to further investigate the possibility of safely removing the residual chemistry that leads not only to the deterioration of the print itself and its visual impact.

## ACKNOWLEDGMENTS

I would like to thank the following individuals for their help with this research project that has now spanned many years: Nora Kennedy, George and Betty Woodman, Malcolm Daniel, Lois Price, Judith Reed, Kate Duffy, Debora Mayer, Dana Mossman Tepper and Mark Sampson.

## REFERENCES

- Azon Corporation . 720 Azon Road, Johnson City, New York [www.amazon.com](http://www.amazon.com). (accessed in 1997).
- Brown, D.J. 1944. The basis and practice of the diazotype process. *Chemistry and Industry*. 16 (April 15): 146-148.
- Chandès, H. 1998. *Francesca Woodman*. Paris: Fondation Cartier pour l'art contemporain.
- Cliffe, W.H. 1958. One hundred years of diazo-compounds: their impact and importance in the chemical industry. *Chemistry and Industry*. 39 (Sept. 27): 1248-1255.
- Duffy, K. 1996. Analytical Laboratory Report # 3659. Winterthur Museum, Winterthur, DE.
- Gabhart, A., R. Krauss and A. Solomon-Godeau. 1986. *Francesca Woodman photographic work*. Exhibition catalogue Wellesley College Museum, Wellesley, MA and Hunter College Art Gallery, New York, NY.
- Kissel, E. and E. Vigneau. 1999. *Architectural photoreproductions: a manual for identification and care*. New Castle, Delaware: Oak Knoll Press.
- Keller, C. (editor). 2011. *Francesca Woodman*. San Francisco: San Francisco Museum of Modern Art in association with Distributed Art Publishers, Inc, New York.
- Kennedy, N. 1997. Personal communication between Nora Kennedy and Betty Woodman. New York, NY.
- Kosar, J. 1965. *Light-sensitive systems: Chemistry and application of nonsilver halide photographic processes*. New York: Wiley.
- Lay, S. 2002. Private communication. [Azon Corporation](http://www.amazon.com), Johnson City, New York.
- Moser, R. (editor). 1950. *Specialty papers: their properties and applications*. Brooklyn, NY: Remsen Press. 226-239.
- Neblette. 1977. *Handbook of Photographs and Reprography*. New York: Van Nostrand Reinhold Co. 427-430.
- Pierini, M. (editor). 2009. *Francesca Woodman*. Milan: Silvana Editoriale.

Reed, J. 1995. Photo-reproductive processes used for the duplication of architectural and engineering drawings: creating guidelines for identification. *The Book and Paper Annual*. 14. 41-49.

Sampson, M. 2013. Personal communication. Mr. Sampson was employed as a technical photographer at Eastman Kodak Company from 1984-2004.

Teledyne Rotolite. 1987. *SL series of convenience copiers operator's manual*. Owen, WI: Teledyne Rotolite, 6-7.

Tate, V. 1974. Diazotype Process. *The Encyclopedia of photography*. 6 New York: Greystone Press. 1149-1150.

Venkataraman, K.. 1952. *The Chemistry of synthetic dyes*, vol.1 and 2. New York: Academic Press, Inc.

Woodman, G. and B. 2002. Personal communication. New York, NY.

Zollinger, Heinrich. 1994. *Diazo chemistry I: aromatic and heteroaromatic compounds*. New York: VCH Publishers.

**Dana C. Hemmenway**  
Library of Congress  
Washington, D. C. USA

Papers presented in *Topics in Photographic Preservation, Volume Fifteen* have not undergone a formal process of peer review.

**APPENDIX****TREATMENT TESTS OF A SAMPLE OF DIAZOTYPE PAPER**

The test samples were acquired from an architect in New York City who had sepia diazotypes from the early 1980's at his disposal. Upon visual examination it contained similar characteristics to the Woodman print: image color, yellow discoloration at the edges, translucency of the paper support and white crease marks.

The sample was used in a number of destructive tests in order to gain insight into its stability in response to exposure to light and various immersion baths such as: water at various pH levels, ethanol, acetone, toluene, and VM&P Naptha solutions.

Small samples were cut to approximately 2 x 5 cm and then cut again lengthwise to yield two strips of diazo paper. The right half was used for testing and the left was retained as a control. Each sample was immersed for five to ten minutes with agitation unless otherwise noted.

Evaluations were made on the basis of visual comparison to the control. The top half was laid over white paper for color comparison, and the bottom half was laid over black paper to evaluate translucency.

**Water Bath 1**                      The bath contained deionized water (pH 5 – used in all aqueous baths) and the sample was immersed for three minutes with agitation. Little if any change was observed.

**Water Bath 2**                      The same conditions as above were used but the sample was left for 10 minutes. A minor lightening of the image color occurred in the washed sample.

**Alkaline Bath 1**                      The pH of this bath was adjusted to 10 with NH<sub>4</sub>OH. The sample noticeably changed. The image color shifted toward a redder brown, and lightened appearing less yellow.

**Alkaline Bath 2**                      The pH of this water bath was adjusted to 12 with NH<sub>4</sub>OH as above. The change between sample and control as described above was more enhanced.

**Acid Bath 1**                              The sample was immersed in water (pH adjusted to 2 with HNO<sub>3</sub>) for five minutes. The image color became lighter and the paper more yellow.

**Ethanol Bath**                              The image color changed; it became much lighter and more yellow. The paper appeared whiter, and there was a loss of the dye density. When viewed against black paper there did not seem to be any change in translucency.

**Acetone Bath**

The image material in this sample changed considerably. During the test, a brown color was observed floating away from the sample. After evaporation of the solvent, some of the released dye remained on the watch glass. Compared to its control, this sample lost a significant amount of color, and the paper appeared brighter. A small portion of its translucency was lost.

**VM&P Naptha**

There was a slight shift in color toward brownish red, the paper base lightened, but the most noticeable change was the loss of translucency.

**Toluene Bath**

The sample shows a shift in color toward a brownish red. The paper base lightened a good deal of its original translucency was lost.

**Light Exposure**

Two samples were prepared; one was encapsulated in polyester to see if the effect of light was in any way related to atmosphere. Each was placed between two pieces of 20pt lignin-free board and secured with a clamp. The board covered half the sample leaving the other half exposed. The test samples were placed in a south-facing window in Texas for approximately one month. The result was a loss of image density and a shift in hue toward yellow. No difference was discerned as a result of encapsulation. Under long-wave ultraviolet radiation, the optical brighteners had diminished in the exposed sample.

**Humidification**

The control and the sample were folded together to create planar deformation for later comparison. The sample was placed in a high humidity chamber for approximately one half hour and then dried under weight. The sample responded quite well to flattening creases with no other noticeable changes.